

SOLACE/SKYLINE

Installation Instructions



Model Numbers: MQHBZDV3636, MQHBZDV4236, MQRB4236, MQRB4236T, HBZDV4736

Stock #s: MQHBZDV3636N, MQHBZDV3636LP, MQHBZDV4236N, MQRB4236N, MQHBZDV4236LP, MQHBZDV3636NE, MQHBZDV3636LPE, MQHBZDV4236NE, MQRB4236NE, MQHBZDV4236LPE
Certified to: ANSI Z21.88-2014 • CSA 2.33-2014 ZERO CLEARANCE VENTED GAS FIREPLACE HEATER

Stock #s: MQRB4236NT, MQRB4236LPT, MQRB4236NTE, MQRB4236LPTE

HBZDV4736N, HBZDV4736LP, HBZDV4736NE, HBZDV4736LPE

Certified to: ANSI Z21.50-2014 • CSA 2.22-2014 ZERO CLEARANCE VENTED GAS FIREPLACE

⚠ WARNING:

FIRE OR EXPLOSION HAZARD

Failure to follow safety warnings exactly could result in serious injury, death, or property damage.

- Do not store or use gasoline or other flammable vapors and liquids in the vicinity of this or any other appliance.
- **WHAT TO DO IF YOU SMELL GAS**
 - Do not try to light any appliance.
 - Do not touch any electrical switch; do not use any phone in your building.
 - Leave the building immediately.
 - Immediately call your gas supplier from a neighbor's phone. Follow the gas supplier's instructions.
 - If you cannot reach your gas supplier, call the fire department.
- Installation and service must be performed by a qualified installer, service agency or the gas supplier.

This appliance may be installed in an aftermarket, permanently located, manufactured home (USA only) or mobile home, where not prohibited by local codes.

This appliance is only for use with the type of gas indicated on the rating plate. This appliance is not convertible for use with other gases, unless a certified kit is used.

INSTALLER: Leave this manual with the appliance.

CONSUMER: Retain this manual for future reference.

For Propane Horizontal installations the venting must be a minimum of one foot vertical off the flue before going horizontal.

! DANGER



HOT GLASS WILL CAUSE BURNS.

DO NOT TOUCH GLASS UNTIL COOLED.

NEVER ALLOW CHILDREN TO TOUCH GLASS.

A barrier designed to reduce the risk of burns from the hot viewing glass is provided with this appliance and shall be installed for the protection of children and other at-risk individuals.



A Division of R-Co. Inc.
2340 Logan Avenue
Winnipeg, Manitoba, Canada R2R 2V3
Ph: (204) 632-1962
Printed in Canada September 4, 2018
Part # 36MQ-MAN14

Table of Contents

Table of Contents.....	2-3
Pre-installation Questions and Answers.....	4
Operating Instructions.....	4
Safety Screen Installation.....	5
Mobile Home/Manufactured Housing Installation.....	6
Warnings, Installations, and Operations.....	7-8
Installation Requirements for the Commonwealth of Massachusetts.....	8
Fireplace Installations in Covered Outdoor Locations.....	9
MQHBZDV3636	
Locating your Appliance.....	10
Fireplace Dimensions.....	10
Framing for your Gas Fireplace.....	11
Framing and Facing Requirements.....	12
Installing Clean View Kit (CVCK).....	13
Clearance to Combustibles.....	13
Parts List.....	14-15
Kingsman Fireplace Venting Parts.....	15
MQHBZDV4236/MQRB4236	
Locating your Appliance.....	16
Fireplace Dimensions.....	16
Framing for your Gas Fireplace.....	17
Framing and Facing Requirements.....	18
Installing Clean View Kit (CVCK).....	19
Clearance to Combustibles.....	19
Parts List.....	20-21
Kingsman Fireplace Venting Parts.....	21
HBZDV4736	
Locating your Appliance.....	22
Fireplace Dimensions.....	22
Framing for your Gas Fireplace.....	23
Framing and Facing Requirements.....	24
Installing Clean View Kit (CVCK).....	25
Clearance to Combustibles.....	25
Parts List.....	26-27
Kingsman Fireplace Venting Parts.....	27
COMMON SECTION	
Clearance, Mantels & Surrounds.....	28-29
Dimensions & Installations of Wall Mount Surrounds.....	30
Fan Installation.....	31
Split Receptacle- Fan Speed Control Outside of Fireplace.....	32
Installing MQRB4236 Liner Panels.....	33
Brick Installation.....	34
Installation of HB Porcelain Liners - HB36PL/HB42PL/HB47PL.....	35
Gas Line Installation.....	36
Millivolt System, Lighting, and Burner Control.....	37
Trouble Shooting The Gas Control System.....	38
Burner System Removal for MQHB36/42/47.....	39
Burner System Maintenance.....	40
Conversion Kit Instructions – PART A.....	41-42
Gas Conversion for Top Convertible Pilot (Series 019065X) – PART B.....	43
Gas Conversion for Modulator – PART C.....	44
Door and Glass Information.....	45
Log Placement - LOGF36.....	46
Pilot Shield RSP1 / RSP2.....	47
MQROCK1/MQRSP2 Setup for Models MQHBZDV3636/MQHBZDV4236.....	48-49
MQROCK1/MQRSP1 Setup for Models HBZDV4736.....	50-51
Accessories Available for Skyline & ZDVRB3622 Ribbon Burner Units.....	52-53
ULK2 Universal Light Kit (Optional Accent Lighting Kit).....	54-55
PROFLAME 1	
Overview and Components.....	56-57
Configuration 1- Basic.....	58

(Continued)

Table of Contents (Continued)

Configuration 2- Remote ON/OFF.....	59
Configuration 3- Remote ON/OFF, Variable Hi/Lo, and Fan.....	60
IPI Lighting Instructions.....	61
PROFLAME 2	
Parts List, GTMFL System.....	62
IFC Module and Remote Control.....	63
Cold Climates – CPI Setting.....	64
Flame Control, Room Thermostat.....	65
Smart Thermostat, Fan Speed Control, Light Control.....	66
Label Schematic.....	67
VENTING SECTION	
Vent Termination.....	68
General Vent Installation Information.....	69
Venting Table.....	70
Installation Of Side Wall Venting.....	71
Vertical Venting.....	72
Glass Safety / Termination Cap Safety- All Units.....	73
Approved for Power Vent PVH58.....	74
PVH58 Power Vent Parts List.....	75
Limited Lifetime Warranty.....	76

Pre-installation Questions and Answers

About curing of the paint

Your stove or fireplace has been painted with the highest quality silicone stove paint. This paint dries quickly in 15-20 minutes when first applied at the factory. However, due to the high temperature silicone components, the paint will cure when heat is applied to the appliance as it is first used. The following information applies to the curing process to get the paint fully hard and durable.

Fire the appliance four successive times for 10 minutes each firing and a 5 minute cool down between each. Be aware during log and firebox paint curing that a white deposit may be developing on the inside of the glass doors. It is important to remove this white deposit from the glass doors using a fireplace glass cleaner.

- Babies, small children, pregnant women and pets should leave the area during the cure phase.
- Ventilate well, open doors and windows.
- Do not touch during curing.

Why does my fireplace or stove give off odour?

It is normal for your fireplace to give off some odor at first. This is due to the curing of the paint, adhesives, silicones and any undetected oil from the manufacturing process as well as the finishing materials used with the installations (e.g. marble, tile and the adhesives used to adhere this product to the walls can react with heat and cause odours).

It is recommended that you burn your gas fireplace or stove for a minimum of four hours at a time with the fan off (if a fan is present) after the curing of the paint has been completed. These odours can last upward to 40 hours of burn time; keep burning at a minimum of four hours per use until odours dissipate.

Noise coming from the fireplace?

Noise is caused by the expansion and contraction of metal as the appliance heats up and cools down. This is normal and is similar to the sounds produced by a furnace or heating duct. This noise does not affect the operation or longevity of your fireplace.

It is also normal for the fan to make some noise when it comes on. This noise can be reduced somewhat by turning down the speed of the fan with the variable speed control. Be aware, however, that this will reduce the volume of heated air circulated into the room by the fan.

Note to the Installer:

Be sure appliance is working properly and its operation (including remote control operation, if included) is fully explained to and understood by the customer.

Operating Instructions

1. Be sure to read and understand all the instructions in this manual before operation of appliance.
2. Ensure all wiring is correct and properly enclosed to prevent possible shock.
3. Check for gas leaks.
4. Make sure the glass door is properly installed before operation. Never operate the appliance with the glass door removed.
5. Make sure venting and termination cap are installed and unobstructed.
6. If brick or porcelain liners are used, ensure they are installed.
7. Verify that the pilot can be seen when lighting the appliance. If not, the log or rock placement is incorrect.
8. If the unit is turned off, you must wait a minimum of 60 seconds before re-lighting it.

Safety Screen Installation Z Series

Contents of Kit:

- [1] Safety Screen
- [2] Side Angles
- [2] Horizontal Angles
- [12-16] DT Screws (Depending on screen size)

Assembly: Attach components with supplied screws as shown.

NOTE: Screens are symmetrical from top to bottom.

⚠ WARNING:

Wait until unit is **COMPLETELY** cool before touching glass or attempting to install or remove Child Safety Screens.

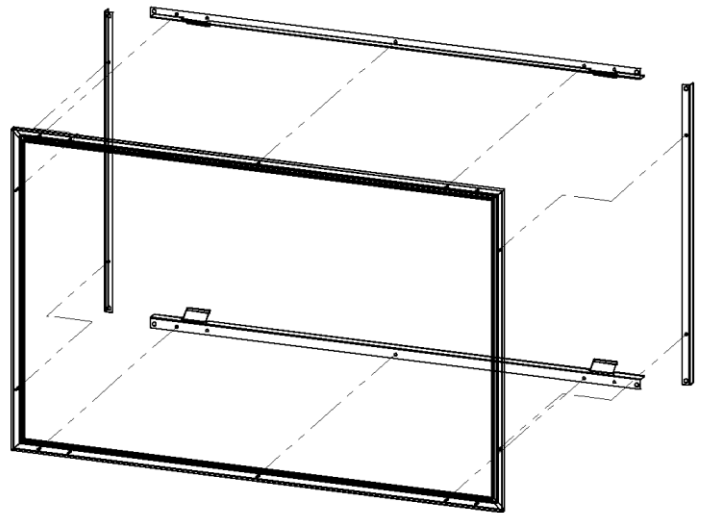

Screen with Side & Horizontal Angles

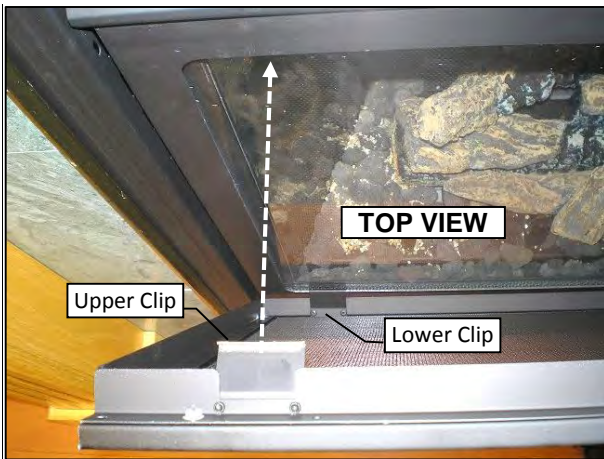

Hook Lower Clip onto glass door frame.

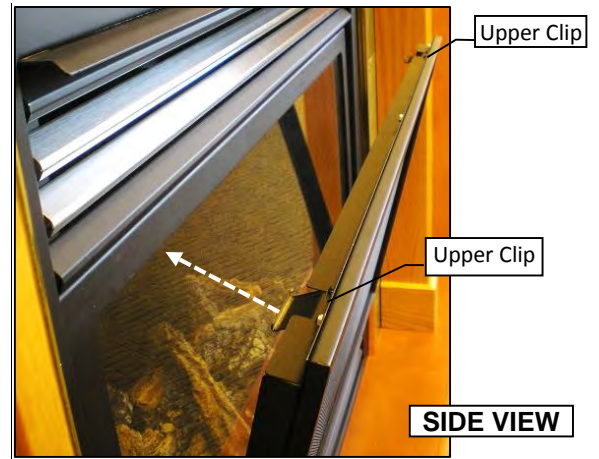

Press down and push upper clip under top glass door frame.

To install screens

hook bottom clip onto glass door frame, then press down and push upper clip under top glass door frame, then release. Clip will hook onto frame.

Fireplace with Screen



To remove Safety Screens
WAIT UNTIL FIREPLACE IS COMPLETELY COOL.

Press down on upper clips and remove screen from fireplace glass door.

Mobile Home/Manufactured Housing Installation

This Direct Vent System Appliance must be installed in accordance with the manufacturer's installation instructions and the Manufactured Home Construction and Safety Standard Title 24 CFR, Part 3280, or the current Standard for Fire Safety Criteria for Manufactured Home Installations, Sites, and Communities ANSI/NFPA 501A, and with CAN/CSA Z240 MH Mobile Home Standard in Canada.

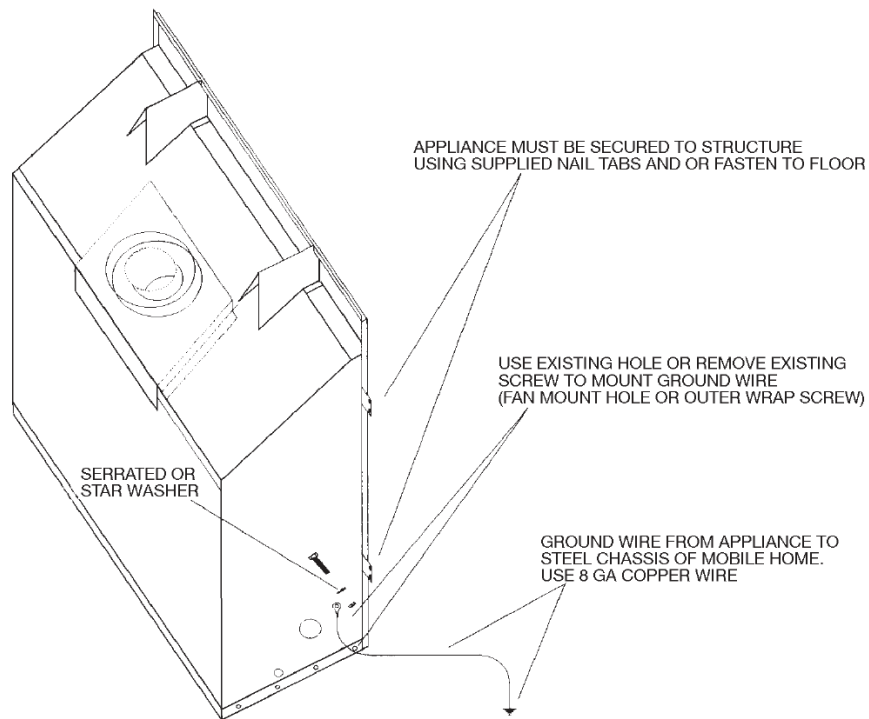

THE VENTED GAS FIREPLACE HEATERS (ANSI Z21.88-2009) IN THIS MANUAL MAY BE INSTALLED IN MANUFACTURED (MOBILE) HOMES AFTER FIRST SALE IN THE USA.

THE VENTED GAS FIREPLACE HEATERS (ANSI Z21.88-2009) IN THIS MANUAL MAY BE INSTALLED IN MANUFACTURED (MOBILE) HOMES IN CANADA.

Please follow the current ANSI/NFPA 70 National Electrical Code in the USA and CAN/CSA C22.1 Canadian National Electrical Code in Canada.

An appliance must be grounded to the steel chassis of the home with 8 ga. copper wire using a serrated or star washer to penetrate paint or protective coating to insure grounding.

Use carriage bolt at the attachment point (see diagram above) to secure the appliance to the floor.



Warning: Do not compromise the structural integrity of the manufactured home wall, floor or ceiling, during installation of appliance or venting.

For required venting components see venting installation in appropriate section of this manual.

Certified for installation in a bedroom or bed/sitting room. In Canada must be installed with listed millivolt thermostat. In USA see local codes.

Warnings, Installations and Operations

Installation Regulations

This gas appliance must be installed by a qualified installer in accordance with local building codes, or in the absence of local codes, with the current CAN/CSA-B149.1 or .2 Installation Code (in Canada) or the current National Fuel Gas Code Z223.1- NFPA 54 when installed in the United States.

This appliance, when installed, must be electrically connected and grounded in accordance with local codes, or in the absence of local codes, with the current CSA C22.1 Canadian Electrical Code or with the National Electrical Code; ANSI/NFPA 70 when installed in the United States.

In the U.S.A. Thermostats are not permitted for Vented Gas Fireplaces (ANSI Z21.50b-Decorative).



WARNING

FOR SAFE INSTALLATION AND OPERATION OF YOUR GAS FIREPLACE PLEASE NOTE THE FOLLOWING:

1. Do not clean when the glass is hot.
2. Do not use abrasive cleaners.
3. Using a substitute glass will void all product warranties.
4. For safe operation, glass doors must be closed.
5. When purging the gas line, the glass front must be removed.
6. Do not strike or abuse glass. Take care to avoid breakage.
7. Do not alter gas orifice.
8. No substitute materials may be used other than factory supplied components.
9. This appliance gives off high temperatures and should be located out of heavy traffic areas and away from furniture and draperies.
10. Children and adults should be alerted to the hazards of the high surface temperatures of this appliance and should stay away to avoid burns or ignition of clothing.
11. Young children should be carefully supervised when they are in the same room as the appliance. Toddlers, young children and others may be susceptible to accidental contact burns. A physical barrier is recommended if there are at risk individuals in the house. To restrict access to a fireplace or stove, install an adjustable safety gate to keep toddlers, young children and other at risk individuals out of the room and away from hot surfaces.
12. Under no circumstances should any solid fuels (wood, paper) be used in this appliance.
13. Under no circumstances should this appliance be modified. Any parts that have to be removed for servicing should be replaced prior to operating this appliance.
14. Any safety screen, guard, or barrier removed for servicing an appliance must be replaced prior to operating the appliance.
15. Installation and repair should be done by a qualified service person. The appliance should be inspected before use and at least annually by a professional service person. More frequent cleaning may be required due to excessive lint from carpeting, bedding material, et cetera. It is imperative that control compartments, burners and circulating air passageways of the appliance be kept clean. Make sure that the gas valve and pilot light are turned off before you attempt to clean this unit.
16. Clothing or other flammable material should not be placed on or near the appliance. This appliance should not be used as a drying rack for clothing nor should Christmas stockings or decorations be hung from it.
17. Do not use this heater if any part has been under water. Immediately call a qualified service technician to inspect the heater and to replace any part of the control system and any gas control which has been under water.
18. Do not operate appliance unless completely installed as per installation instructions.
19. Failure to position the parts in accordance with these diagrams or failure to use only parts specifically approved with this appliance may result in property damage or personal injury.
20. **WARNING: Do not operate appliance with the glass front removed, cracked or broken. Replacement of the glass should be done by a licensed or qualified service person.**
21. The appliance area must be kept clear and free from combustible materials, gasoline, and other flammable vapors and liquids.
22. The front of the fireplace gives off high temperatures that could ignite combustible material which is kept close to the front of the unit.
23. Ensure that power to the Fireplace is turned off before servicing.
24. Do not operate this Fireplace without the glass front or with a broken glass.
25. Improper installation, adjustment, alteration, service or maintenance can cause injury or property damage. Refer to the owner's information manual provided with this appliance. For assistance or additional information consult a qualified installer, service agency, or the gas supplier.
26. Operation of this appliance when not connected to a properly installed and maintained venting system or tampering with the blocked vent shutoff system can result in carbon monoxide (CO) poisoning and possible death.
27. This appliance is equipped with a three-prong (grounding) plug for your protection against shock hazard and should be plugged directly into a properly grounded three-prong receptacle. Do not cut or remove the grounding prong from this plug.

DANGER

HOT GLASS WILL CAUSE BURNS.
DO NOT TOUCH GLASS UNTIL COOLED.
NEVER ALLOW CHILDREN TO TOUCH GLASS.

A barrier designed to reduce the risk of burns from the hot viewing glass is provided with this appliance and shall be installed for the protection of children and other at-risk individuals.

- Gas fired appliances may be used only for supplemental heat and/or decorative purposes and under no circumstances shall they provide a primary heat source.
- This appliance must not be connected to a chimney flue serving a separate solid-fuel burning appliance.

NOTE: It is recommended that a Carbon Monoxide (CO) Detector be installed in or near bedrooms and on all levels of your home. Place a detector about 15ft [4.5m] outside the room that houses your gas appliance.

Certified for installation in a bedroom or bed/sitting room. In Canada must be installed with listed millivolt thermostat.

In the U.S.A. Thermostats are not permitted for Vented Gas Fireplaces (ANSI Z21.50b-Decorative).

In USA see local codes.

Operations and Maintenance Instructions

For safe installation and operation note the following:

- Venting systems should be periodically examined by a qualified agency.
- The flow of combustion and ventilation air must not be obstructed.
- The Burner/Log Assembly has been engineered and permanently adjusted for proper flame control.
- Periodically remove the logs from the grate assembly and vacuum any loose particles from the grate and burner areas. See Log Placement page to remove logs. Vacuum burner parts and replace logs.
- Never use your gas fireplace as a cooking device.
- Label all wires prior to disconnection when servicing controls. Wiring errors can cause improper and dangerous operation. Verify proper operation after servicing.

Installation Requirements for the Commonwealth of Massachusetts

In the Commonwealth of Massachusetts, the installer or service agent shall be a plumber or gas fitter licensed by the Commonwealth. When installed in the Commonwealth of Massachusetts or where applicable codes; the unit shall be installed with a CO detector per the requirements listed below.

1. For direct-vent appliances, mechanical-vent heating appliances or domestic hot water equipment, where the bottom of the vent terminal and the air intake is installed below four feet above grade the following requirements must be satisfied:
 - A. If there is not one already present, on each floor level where there are bedroom(s), a carbon monoxide detector and alarm shall be placed in the living area outside the bedroom(s). The carbon monoxide detector shall comply with NFPA 720.
 - B. A carbon monoxide detector shall be located in the room that houses the appliance or equipment and shall:
 - Be powered by the same electrical circuit as the appliance or equipment such that only one service switch services both the appliance and the carbon monoxide detector;
 - Have battery back-up power;
 - Meet ANSI/UL 2034 Standards and comply with NFPA 720; and
 - Have been approved and listed by a Nationally Recognized Testing Laboratory as recognized under 527 CMR.
 - C. A Product-approved vent terminal must be used, and if applicable, a Product-approved air intake must be used. Installation shall be in strict compliance with the manufacturer's instructions. A copy of the installation instructions shall remain with the appliance or equipment at the completion of the installation.
 - D. A metal or plastic identification plate shall be mounted at the exterior of the building, four feet directly above the location of vent terminal. The plate shall be of sufficient size to be easily read from a distance of eight feet away, and read "Gas Vent Directly Below".
2. For direct-vent appliances, mechanical-vent heating appliances or domestic hot water equipment where the bottom of the vent terminal and the air intake is installed above four feet above grade the following requirements must be satisfied:
 - A. If there is not one already present, on each floor level where there are bedroom(s), a carbon monoxide detector and alarm shall be placed in the living area outside the bedroom(s). The carbon monoxide detector shall comply with NFPA 720.
 - B. A carbon monoxide detector shall:
 - Be located in the room that houses the appliance or equipment;
 - Be either hard-wired or battery powered or both; and
 - Shall comply with NFPA 720.

A Product-approved vent terminal must be used, and if applicable, a Product-approved air intake must be used. Installation shall be in strict compliance with the manufacturer instructions. A copy of the installation instructions shall remain with the appliance or equipment at the completion of the installation.

For the state of Massachusetts a **T-handle gas shut-off valve** must be used on a gas appliance. This T-handle gas shut-off valve must be listed and approved by the state of Massachusetts. This is in reference to the state of Massachusetts state code CMR238.

Fireplace Installations in Covered Outdoor Locations



Kingsman and Marquis Direct Vent fireplaces may be installed into outdoor locations provided they are suitably protected from direct water impingement.

However, all installation clearances in the appliance manual must be observed. Framing, Clearances to Combustibles, Mantel Heights, Facing Requirements, Venting Installation, etc. **Use supplied Safety Screen.**

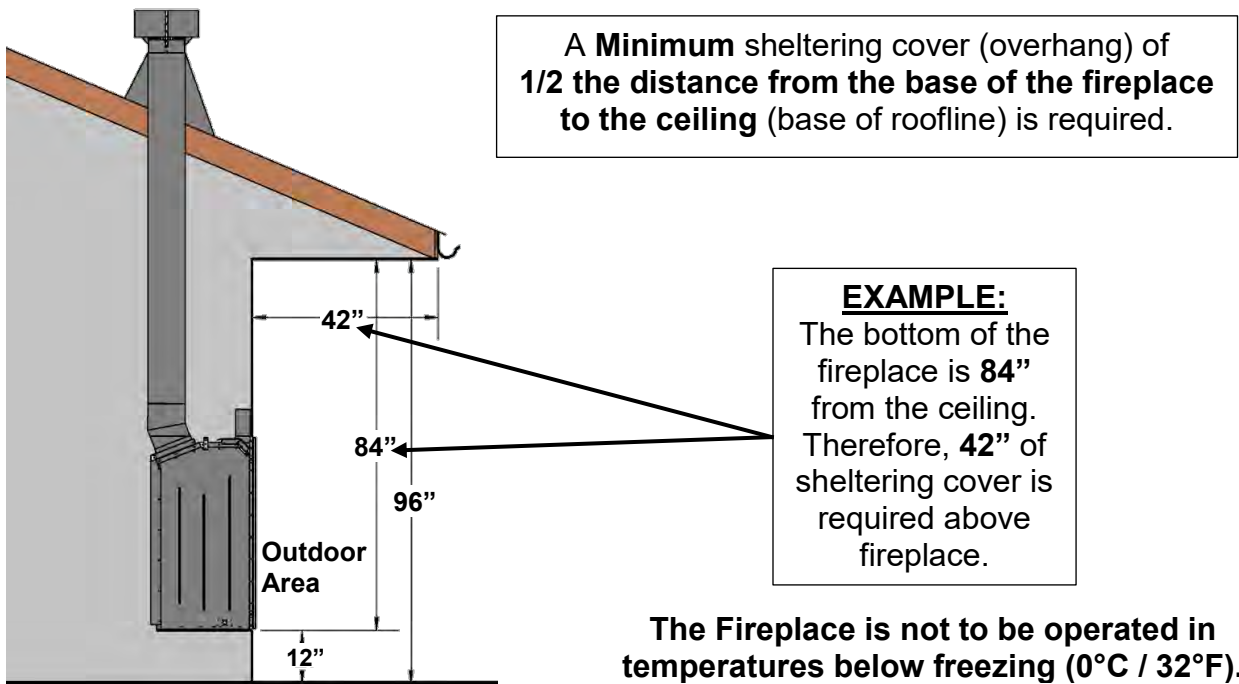
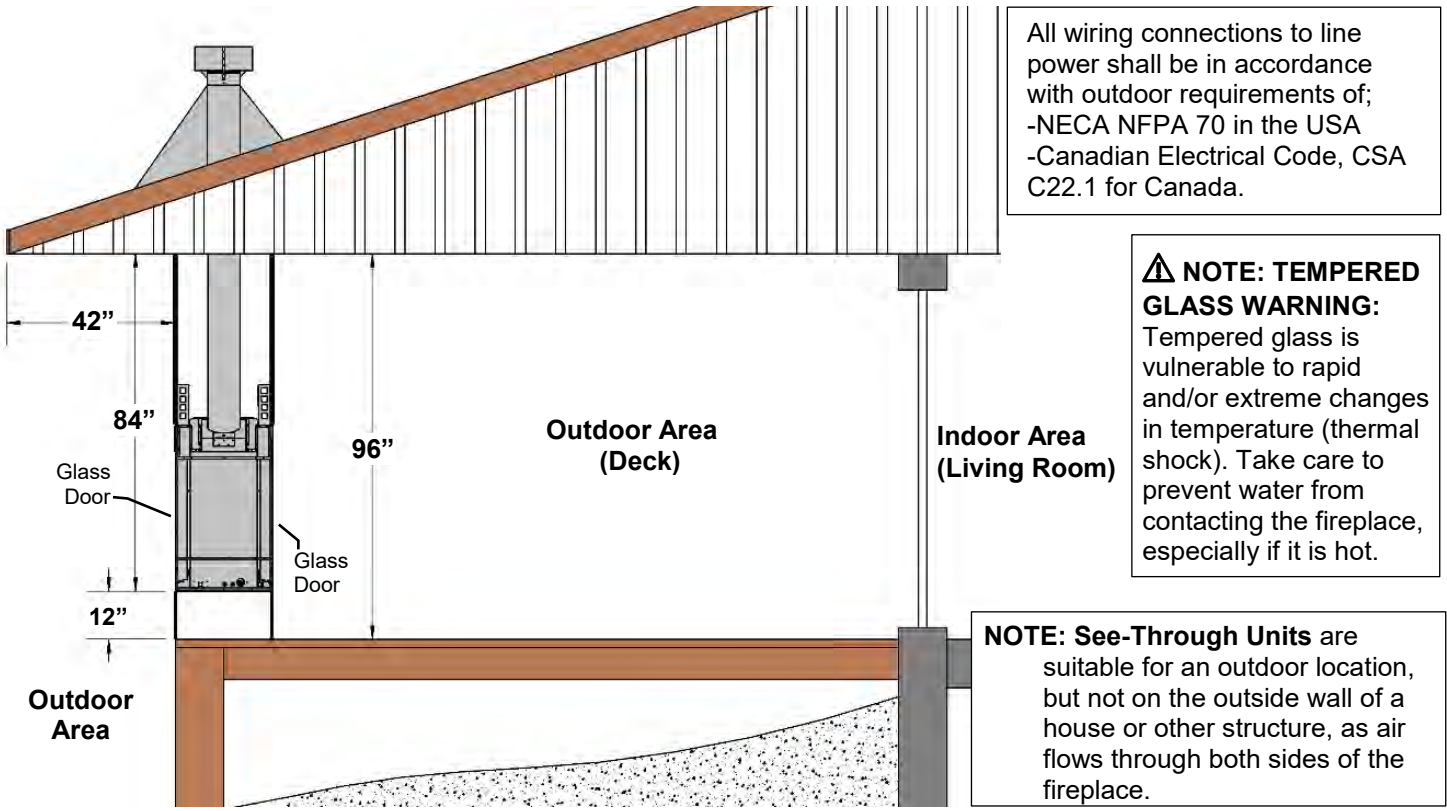

Locating Your Appliance

LOCATION KEY:

- A. Flat on Wall
- B. Across the Corner
- C. As an Island
- D. As a Room Divider
- E. Flat on Wall Corner
- F. Exterior Wall

See Mantel Leg Clearances Instruction for the proper placement of fireplace.

Island installation with a top vent is possible as long as the horizontal portion of the vent system does not exceed 20 feet (6.1 m).

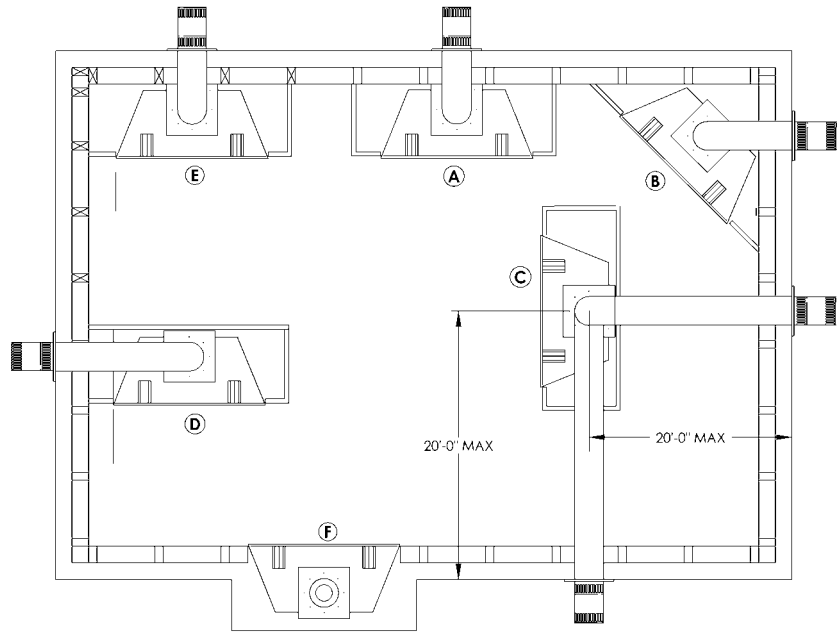

Fireplace Dimensions

HBZDV36

HBZDV36-CVCK

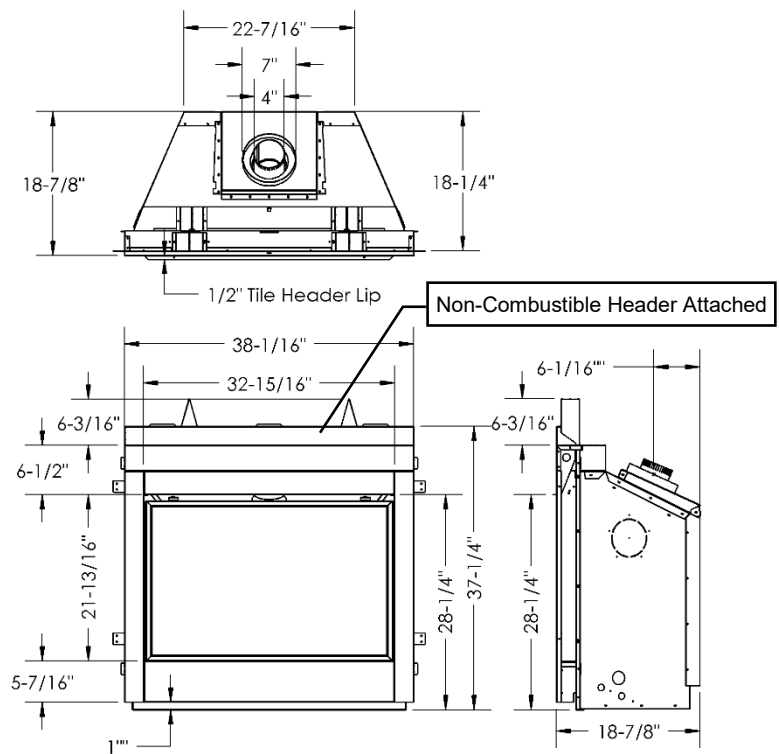
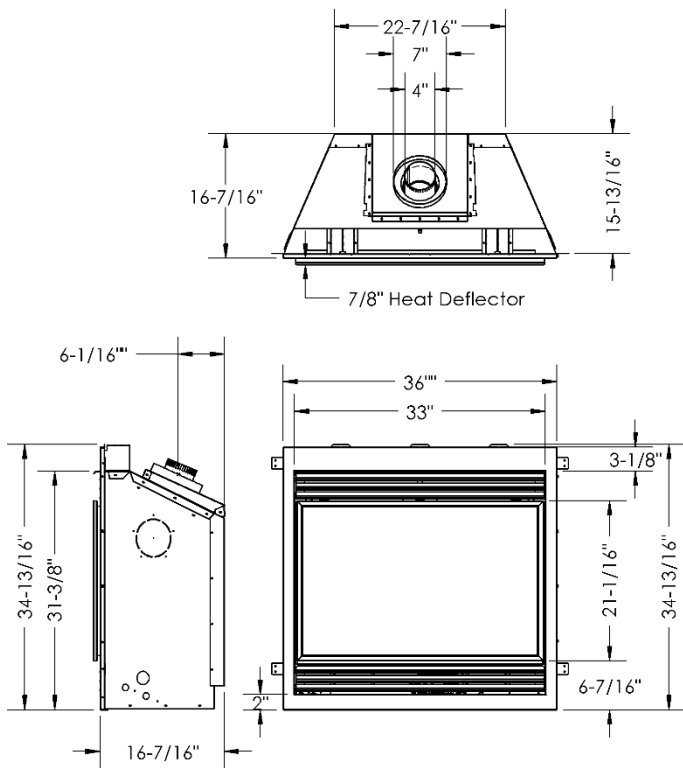

MQHBZDV3636 - Framing for your Gas Fireplace

Framing Specifications

1. Cold climate installation recommendation: When installing this fireplace against non insulated exterior wall or chase, it is recommended that the outer walls be insulated to conform to applicable insulation codes. Drywall must be installed over insulation to prevent contact of insulation and unit.
2. Choose fireplace location and frame in accordance with the fireplace framing dimensions specified (See Framing Diagrams). Bend nailing tabs forward on left and right of unit and place fireplace into framed enclosure. This allows for 1/2" in front of framing tabs for finishing materials.
3. Drywall or other material can extend flush with the appliance on the bottom, sides and top of fireplace. (louvered models only)
4. When installing horizontal with a 90 degree bend maintain a minimum of two and a half (2.5") inches above the bend in enclosures.
5. For a fireplace with louvers combustible floor can raise 1" above the bottom of the fireplace. For a fireplace with HB36CVCK (Clean view Circulating Kit) floor or hearth can raise 7" above the bottom of the fireplace with portions being combustible and non combustible. See drawing on following page.
6. When installing MQHB36SW surround, the fireplace must be raised a minimum of 3 1/2" above the finished floors, to accommodate the wall surround. The fireplace may be raised higher but the 60" clearance measured from the bottom of the fireplace to the ceiling must be maintained at all times. (i.e. For an 8 ft. ceiling the unit can be raised only 36 inches.)

For **Propane Horizontal Installations** the venting must be a minimum of one foot vertical off the flue before the elbow on any horizontal runs of one foot or greater. This allows for cleaner combustion and greatly reduces carboning and cleaning of glass.

MQHBZDV36 Louvered

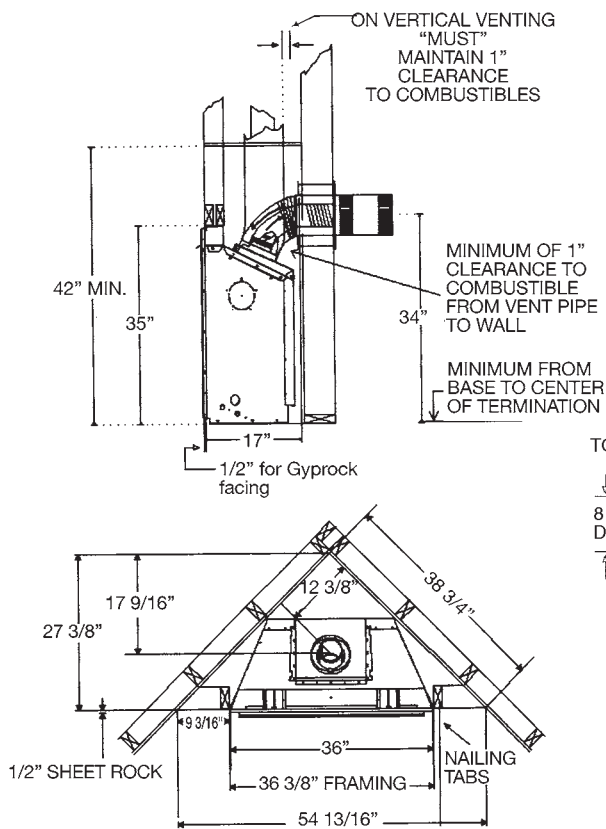

MQHBZDV36 WITH HB36CVCK (CLEAN VIEW CIRCULATING KIT)

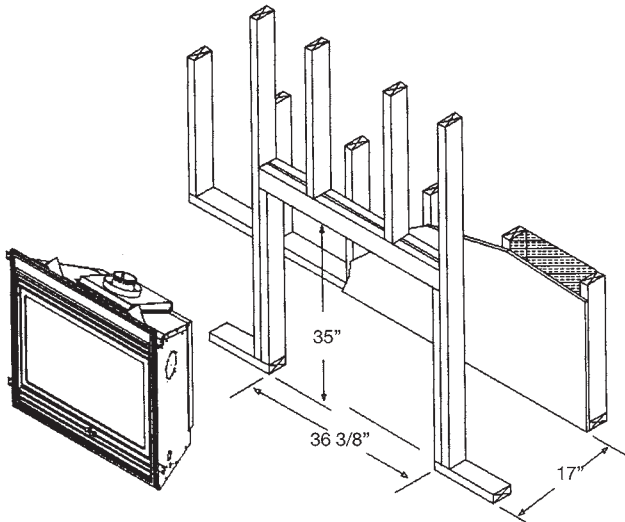
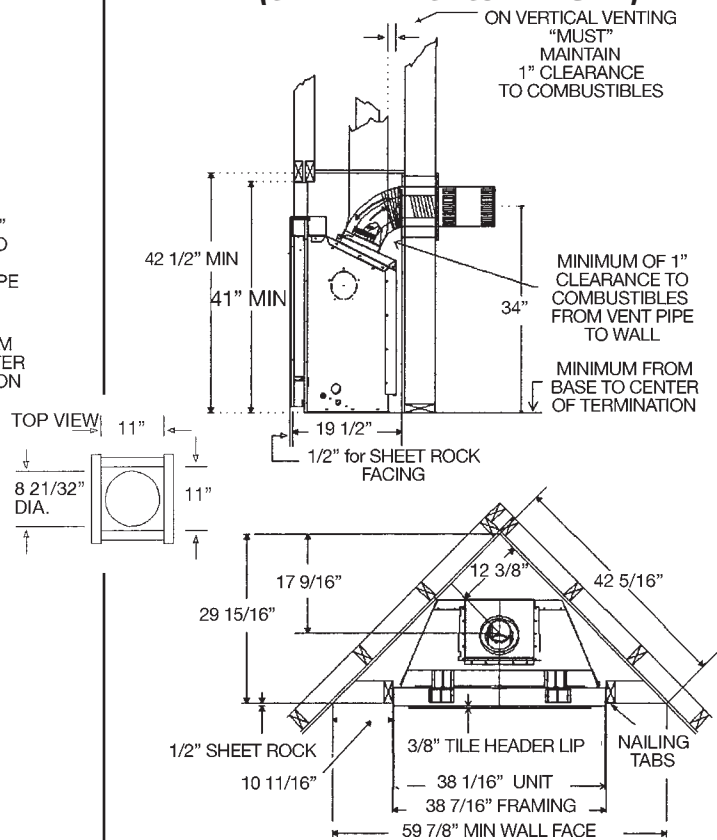

NOTE: When adding a MQHB36SW wall surround, the fireplace must be raised a minimum of 3 1/2" above the finished floor to accommodate the wall surround. (See next page)

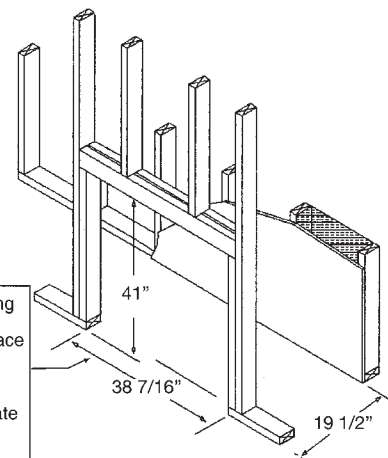

HBZDV36 - Framing and Facing Requirements

HBZDV36 WITH HB36CVCK (CLEAN VIEW CIRCULATING KIT)

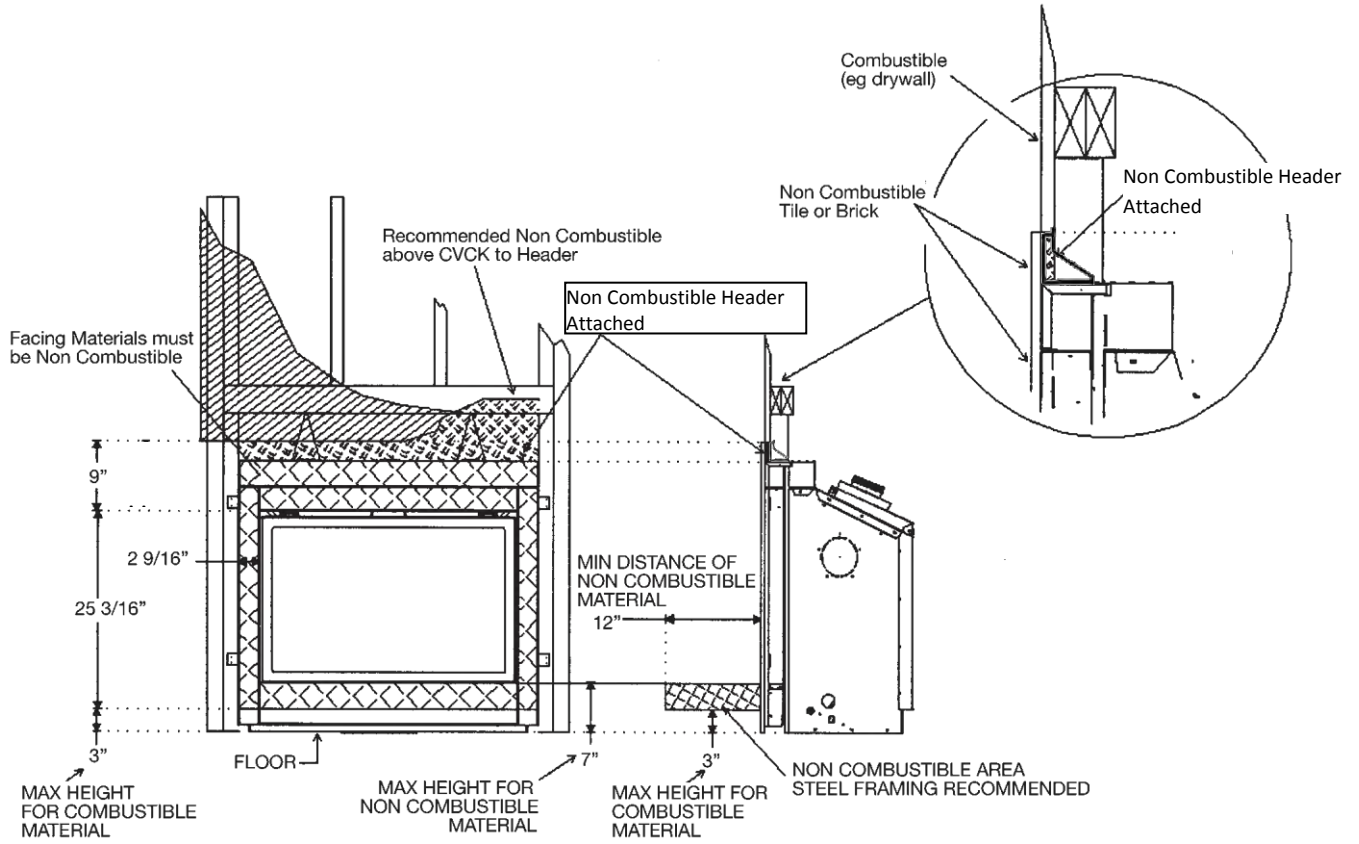

HB36CVCK WITH MQHB36SW SURROUND

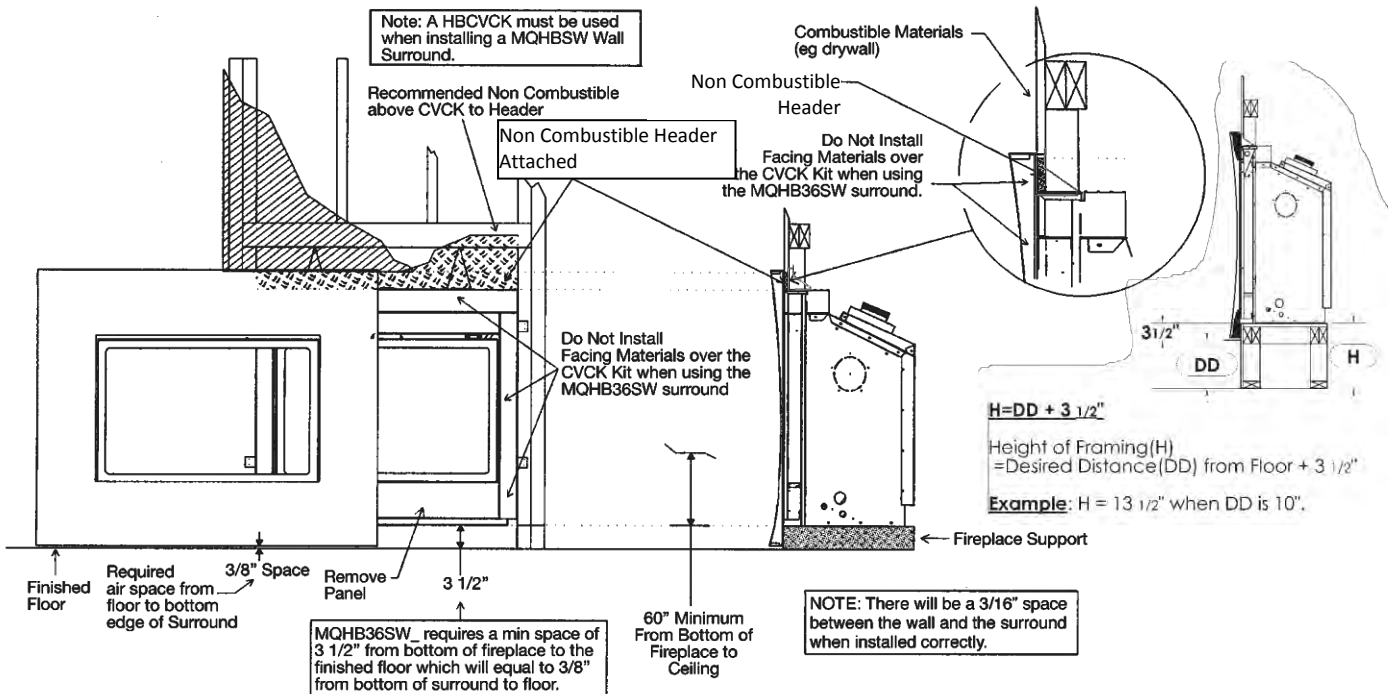

HB36 - How to Install Clean View Kit (CVCK)

CAUTION: When using CVCK DO NOT INSTALL a Louver assembly.

1. Install optional fan kit (see Fan Instruction).
2. Fold two standoffs up into position and mount with supplied screws. (FIG 1)
3. Hang CVCK on top of fireplace retainer tabs and rotate down into position. (FIG 2)
4. **If not factory pre-installed**, use the screws provided to fasten the non-combustible header onto the top of the CVCK assembly.
5. Using four supplied #6 screws, fasten CVCK kit to the inside frame of unit.
6. Kit is supplied with 2 valve extension knobs. Align the notches and slide the extensions onto valve knobs.
7. DO NOT brick or tile beyond the inside area of the CVCK kit to allow for removal of door.
8. Install optional pull screen system: First slide curtain onto rods and slide round end of rod into side post (REF A). Using 1/2" DT screws, mount the flattened end of rod to bottom side of rod hanger bracket (REF B). Repeat this step for opposite side.

NOTE: ADDITIONAL ACCESS FOR GASLINE INSTALLATION AND FAN ELECTRICAL INSTALLATION! When CVCK is installed in framing, remove 2 screws from the right and left side of the bottom panel (REF C). Once screws are removed, bottom panel can be rotated forward for access to gas valve and fan system.

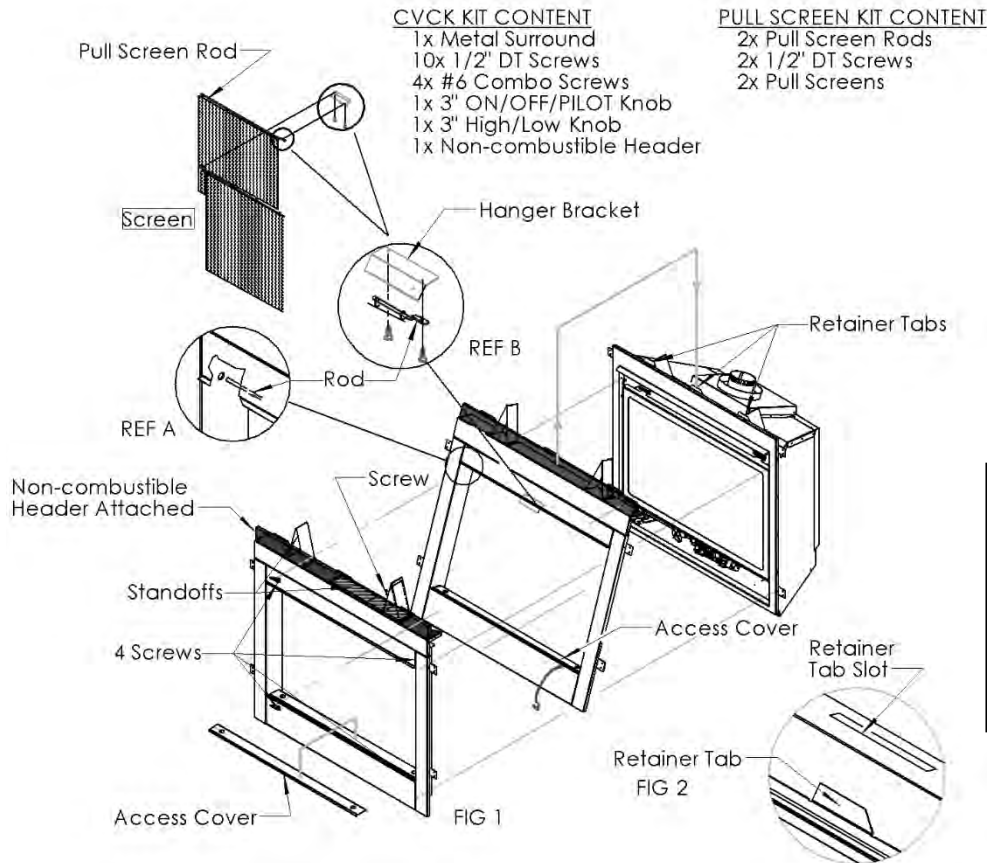

WARNING: Failure to position the parts in accordance with these diagrams or failure to use only parts specifically approved with this appliance may result in property damage or personal injury.

NOTE: When using the Clean View Kit (CVCK) and installing optional electrical components (i.e. Remote Controls, variable speed control, and or fan modules) locate them in the Clean View access area, unless other shielding devices like our IPI Component box is used.

Clearance to Combustibles

Back (from Standoffs)	0 inches/0 mm
Side (from standoffs)	0 inches/0 mm
Floor	0 inches/0 mm
Ceiling (from bottom of fireplace)	60 inches/150 cm
Top (from standoffs)	0 inches/0 mm
Top of 90 degree bend in Minimum Enclosure of 42 to 43 inches	3 1/2 inches/89 mm / All Vent Systems
Top of 90 degree bend in Enclosure over 43 inches	2 1/2 inches/64 mm / All Vent Systems
Top of Horizontal Pipe	1 1/2 inches/38 mm / All Vent Systems
Side & Bottom of Horizontal Pipe	1 inch/25.5mm / All Vent Systems
Vertical Vent Pipe	1 inch/25.5mm / Kingsman Vent Systems
Vertical Vent Pipe	1 1/4 inch/32mm / Simpson/AmeriVent/Selkirk Direct Temp Systems

(NOTE -Floor) if installing the appliance directly on carpeting or other combustible materials other than wood flooring, the appliance shall be installed on a metal or wood panel, the full width and depth of the appliance. Carpet may extend 1 inch above the floor of appliance.
For units with CVCK (Clean View Circulating Kit) see framing with CVCK to establish floor heights

HBZDV3636 Parts List

Fireplace Part Numbers

HBZDV3636N (Millivolt) HBZDV3636NE (IPI)	Fireplace Heater Rated NG, Ceramic Glass, 30,500 BTU AT 75% efficient. Approved for bedroom and mobile home.
HBZDV3636LP (Millivolt) HBZDV3636LPE (IPI)	Fireplace Heater Rated LP, Ceramic Glass, 29,200 BTU AT 75% efficient. Approved for bedroom and mobile home.

FIREPLACE REQUIREMENTS

Grills - OR - CVCK (clean view circulating kit) Required for each unit

HB36CVCK	CVCK(clean view circulating kit) no grill required
HB36GBA	Grill Kit - Classic Builder Antique Brass
HB36GBC	Grill Kit - Classic Builder Chrome
HB36GBP	Grill Kit - Classic Builder Polish Brass
HB36GBL	Grill Kit - Black
HB36PBL	Panel Grill Kit - Black

LOG SETS/ROCK KITS: (Required for each unit)

LOGF36	Log Set - 7 pc. - /Fibre Split Oak
MQROCK1	Rock Set Tan (HBZDV/MQRB)
MQROCK2	Rock Set Natural (HBZDV/MQRB)
MQROCK3	Rock Set Multi-Color (HBZDV/MQRB)
MQRSP2	Rock Platform, Support, and 4 Screws (MQHBZDV3636, 4236)

Safety Screens

HB36CSS	Safety Screen Replacement
HB36PSK	Pull Screen Kit for CVCK

Optional Fan Kit / Blower

Z36FK	Fan Kit w/Variable Speed Wall Mount Control (Temperature Sensing)
-------	---

Replacement Burner Assembly

3636MQ-BNGSI	Burner Assembly - Natural Gas c/w Valve System (HBZDV3636N)
3636MQ-BLPSI	Burner Assembly - Natural Gas c/w Valve System (HBZDV3636LP)

Conversion Kit (Sit Valve Only)

3632HB-CKLP	LP Conversion Kit for HBZDV3632/3636 (Millivolt)
3632HB-CKNG	NG Conversion Kit for HBZDV3632/3636 (Millivolt)

Valve System Parts - Top convertible SIT (Millivolt)

1000-P136WR	Generator / Thermopile
1001-P069SI	Electrode Sparker 915.069 TC SIT
1001-P216SI	Thermocouple 290.216 TC SIT
1001-P165SI	Orifice Pilot NG 977.165 TC SIT
1001-P167SI	Orifice Pilot LP 977.167 TC SIT
1001-P633SI	Valve Nova LP Hi/Lo 0820651
1001-P634SI	Valve Nova NG Hi/Lo 0820652
1001-P713SI	Pilot Burner LP 199.713 TC SIT
1001-P714SI	Pilot Burner NG 199.714 TC SIT

Remote Control / Millivolt

Z1MT	Thermostat Millivolt Wall Mount
------	---------------------------------

Z80PT	Thermostat Programmable Digital Millivolt Wall Mount (1F80-40)
GTRC	Remote Control Millivolt - Thermostat
GTMRCP	Remote Control Millivolt - Thermostat/Modulating - LP
GTMRCN	Remote Control Millivolt - Thermostat/Modulating - NG
GTFRCF	Remote Control Millivolt - Thermostat/Modulating/Fan - LP
GTFRCN	Remote Control Millivolt - Thermostat/Modulating/Fan - NG
DCHS	Remote Control Heatshield

Electronic Ignition/Remote Control IPI

EGTRC	Remote Control IPI (Thermostat)
EGTMRCN	Remote Control IPI (Thermostat/Modulating - NG)
EGTMRCP	Remote Control IPI (Thermostat/Modulating - LP)
EGTFRCN	Remote Control IPI (Thermostat/Modulating/Fan - NG)
EGTFRCF	Remote Control IPI (Thermostat/Modulating/Fan -LP)

Electronic Ignition Replacement Parts IPI

1006-P002si	Valve IPI (NG; Hi/Lo)
1006-P003si	Valve IPI (LP; Hi/Lo)
1002-P047si	Pilot Assembly (LP)
1002-P033si	Pilot Assembly (NG)
1002-P089si	Spark Electrode (Long)
1002-P113si	Electrode Flame Sensor (Long)
1002-P302si	IPI Ignition Board
1002-P850si	AC Wall Adapter
1002-P12BH	Battery Pack
1002-P912si	Wiring Harness
1001-P166si	Orifice Pilot (NG)
1001-P168si	Orifice Pilot (LP)
1002-P013si	Stepper Motor (NG)
1002-P012si	Stepper Motor (LP)
1002-P016si	Hi/Lo Regulator (NG)
1002-P014si	Hi/Lo Regulator (LP)

Miscellaneous Parts

1000-150GE	Silicone GE Red IS806 #736
1000-150MP	Hi-Temp Millpac Sealant 840099
1000-214	Piezo-Igniter 1244-17 MARK 21
1000-215	Pal Nut (18MMXI.5MM)BLK (1364.03)
1000-218	Switch Ivory (1451/001)
1000-227	Cover Ivory (86001/001)
1000-255	Orifice Brass - (State Size)
2000-080	Thermodisc 2450 (For Blower)
1000-306	Thermalcord - Adhesive Back for Door Frame
1000-085	Control Variable Speed KBWC-13BV
FP15GC	Stainless Steel Gas Connector
VLBIT4	Log Bits - Large Four Piece Kit
VLBIT6	Log Bits - Small Six Piece Kit
1000-EMBER	Moon Rock
2000-081	Blower Motor QLN65/2400
36HB-310	Ceramic Glass - For All HBZDV3600
36HB-123	Upper Door Spring

Refractory Liners

HB36PL	Porcelain Reflective Liner
HB36RLC	Refractory Liner Classic
HB36RLT	Refractory Liner Traditional
HB36RLH	Refractory Liner Herring Bone

MQHBZDV3636 Parts List

Electronic Ignition Replacement Parts IPI

1002-P001si	Valve IPI (NG; ON/OFF)
1002-P002si	Valve IPI (LP; ON/OFF)
1006-P002si	Valve IPI (NG; Hi/Lo)
1006-P603si	Valve IPI (LP; Hi/Lo)
1002-P047si	Pilot Assembly (LP)
1002-P033si	Pilot Assembly (NG)
1002-P089si	Spark Electrode (Long)
1002-P113si	Electrode Flame Sensor (Long)
1002-P302si	IPI Ignition Board
1002-P850si	AC Wall Adapter
1002-P12BH	Battery Pack
1002-P912si	Wiring Harness
1002-P166si	Orifice Pilot (NG #62)
1002-P168si	Orifice Pilot (LP #35)
1002-P013si	Stepper Motor (NG)
1002-P012si	Stepper Motor (LP)
1002-P016is	Hi/Lo Regulator (NG)
1002-P014si	Hi/Lo Regulator (LP)

Miscellaneous Parts

1000-150GE	#Silicone GE Red IS806 #736
1000-150MP	#Hi-Temp Millpac Sealant 840099
1000-214	#Piezo-Igniter 1244-17 MARK 21
1000-215	#Pal Nut (18MMX1.5MM)BLK (1364.03)
1000-218	#Switch Ivory (1451/001)
1000-227	#Cover Ivory (86001/001)
1000-255	#Orifice Brass - (State Size)
1000-EMBER	#Moon Rock
2000-080	#Thermodisc 2450 (For Blower)
2000-081	#Blower Motor QLN65/2400
1000-085	#Control Variable Speed KBWC-13BV
1000-306	Thermalcord - Adhesive Back for Door Frame
36HB-310	Ceramic Glass - For All HBZDV3600
36HB-123	Upper Door Spring

Kingsman Fireplace Venting

Catalog Number Description

ZDVHSK	Horizontal Vent Starter Kit - 3 FT Length Horizontal Vent Termination, Wall Thimble, 36" Flex Pipe, Mill Pac, screws/washers, springs.
ZDVHSK5	Horizontal Vent Starter Kit - 5 FT Length Horizontal Vent Termination, Wall Thimble, 60" Flex Pipe, Mill Pac, screws/washers, springs.
FDVVT40	Vertical Vent Termination converts from 15'-40' to under 15'
FDVHT	Horizontal Vent Termination
FDVHSQ	Horizontal Square Termination
ZDVST	Horizontal Snorkel Termination (34" Tall, 24" Center to Center)
FDVHSCU	Safety Cage for Horizontal Termination
ZDVAIS	Attic Insulation Shield
ZDVVOS	Offset Support
ZDVFS	Firestop Spacer
ZDVRS	Roof Support
ZDVWT	Wall Thimble (Horizontal Venting)
ZDVSSLR	Siding Shield - Large Return
ZDV48GP	Galvanized Pipe 7" Dia. x 48" (Vertical Installations)
ZDVAAF	Flashing 7" c/w Storm Collar (1/12 to 7/12)
ZDVAF2	Flashing 7" c/w Storm Collar (8/12 to 12/12)
ZDVAF3	Flashing 7" c/w Storm Collar Flat
ZDV7SC	Storm Collar 7"
ZDVFK5	Flex Kit (4" & 7" Dia.) x 2.5' (Unexpanded) 5' Expanded
ZDVFK8	Flex Kit (4" & 7" Dia.) x 4' (Unexpanded) 8' Expanded
ZDVFK20	Flex Kit (4" & 7" Dia.) x 10' (Unexpanded) 20' Expanded *Kits are complete with spring stand-offs, silicone.
ZDV4FC	Flex Connector 4" Diameter
ZDV7FC	Flex Connector 7" Diameter
ZDV4SS	Spring 4" Standoff Spacer
ZDVDFFA	Simpson Dura-Vent Fireplace Adapter (for ZDV33/36/42/47, ZDV6000, MDV31 & HB models)
ZDVHSKSQ	Horizontal Square Termination Vent Starter Kit - 3 FT Length Horizontal Vent Termination, Wall Thimble, Wall Thimble, 36" Flex Pipe, Mill Pac
ZDVHSKSQ5	Horizontal Square Termination Vent Starter Kit - 5 FT Length Horizontal Vent Termination, Wall Thimble, Wall Thimble, 60" Flex Pipe, Mill Pac
FDVHSQ	Horizontal Square Vent Termination

Locating Your Appliance

LOCATION KEY:

- A. Flat on Wall
- B. Across the Corner
- C. As an Island
- D. As a Room Divider
- E. Flat on Wall Corner
- F. Exterior Wall

See Mantel Leg Clearances Instruction for the proper placement of fireplace.

Island installation with a top vent is possible as long as the horizontal portion of the vent system does not exceed 20 feet (6.1 m).

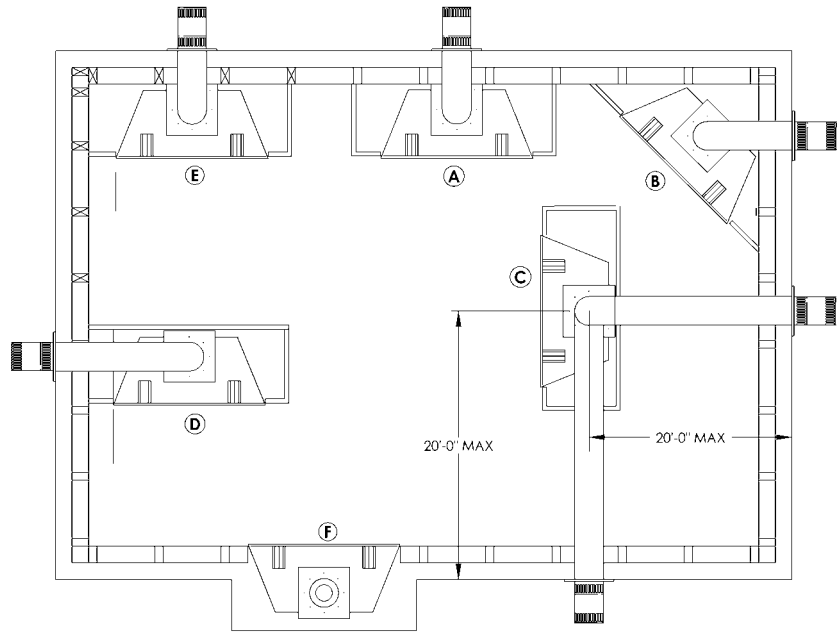

Fireplace Dimensions

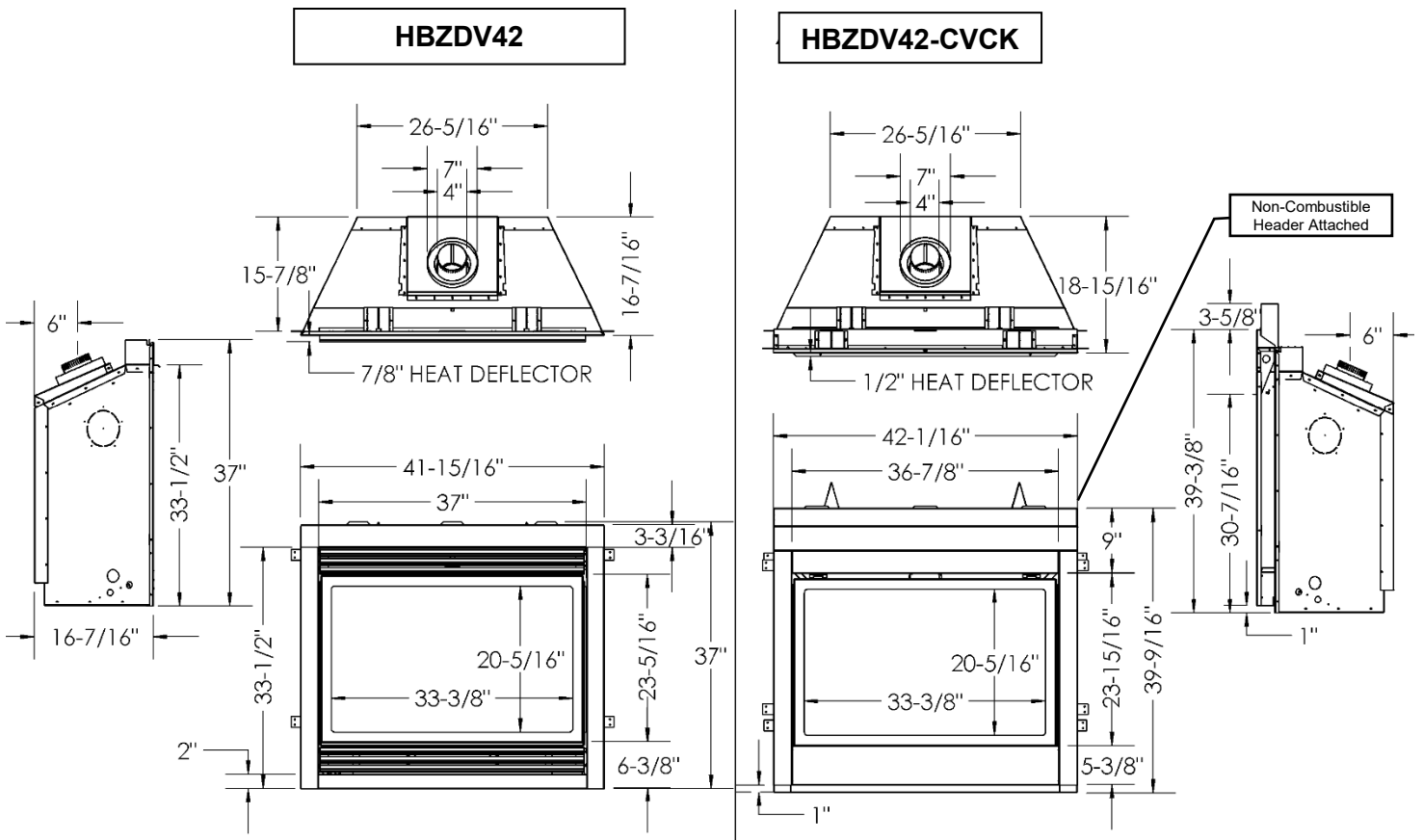

MQHBZDV4236/MORB4236 - Framing for your Gas Fireplace

Framing Specifications

1. Cold climate installation recommendation: When installing this fireplace against non insulated exterior wall or chase, it is recommended that the outer walls be insulated to conform to applicable insulation codes. Drywall must be installed over insulation to prevent contact of insulation and unit.
2. Choose fireplace location and frame in accordance with the fireplace framing dimensions specified (See Framing Diagrams). Bend nailing tabs forward on left and right of unit and place fireplace into framed enclosure. This allows for 1/2" in front of framing tabs for finishing materials.
3. Drywall or other material can extend flush with the appliance on the bottom, sides and top of fireplace. (louvered models only)
4. When installing horizontal with a 90 degree bend maintain a minimum of two and a half (2.5") inches above the bend in enclosures.
5. For a fireplace with louvers combustible floor can raise 1" above the bottom of the fireplace. For a fireplace with HB42CVCK (Clean view Circulating Kit) floor or hearth can raise 7" above the bottom of the fireplace with portions being combustible and non combustible. See drawing on following page.
6. When installing MQHB42SW surround, the fireplace must be raised a minimum of 3 1/2" above the finished floors, to accommodate the wall surround. The fireplace may be raised higher but the 60" clearance measured from the bottom of the fireplace to the ceiling must be maintained at all times. (i.e. For an 8 ft. ceiling the unit can be raised only 36 inches.)

It is recommended for **Propane Horizontal Installations** that the venting should be a minimum of one foot vertical off the flue before the elbow on any horizontal runs of one foot or greater. This allows for cleaner combustion and greatly reduces carboning and cleaning of glass. (Does not apply to Back Flue Models).

MQHBZDV42/MORB4236 louvered

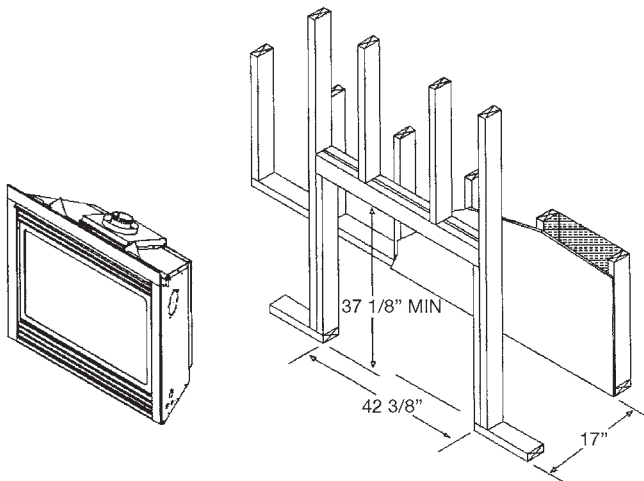
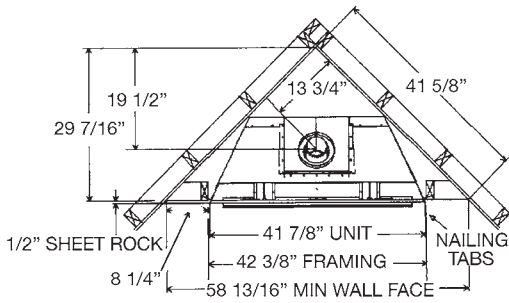
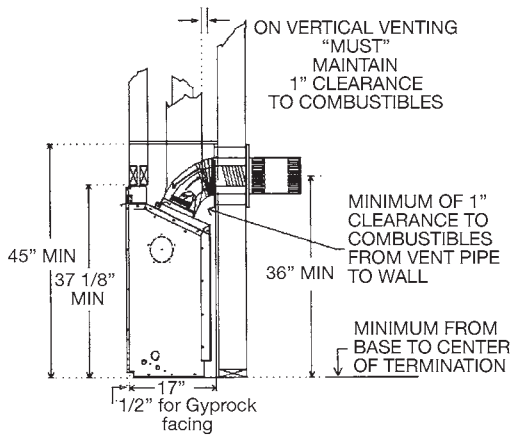

MQHBZDV42/MORB4236 WITH HB42CVCK (CLEAN VIEW CIRCULATING KIT)

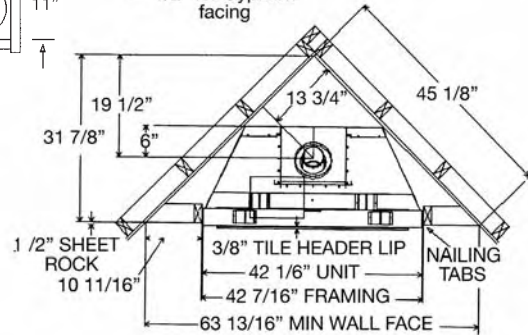
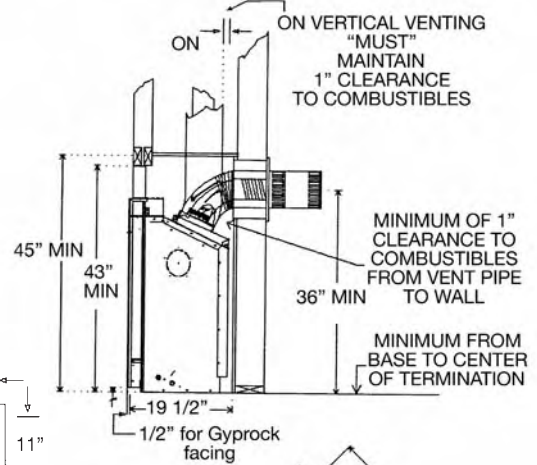

NOTE: When adding a MQHB42SW wall surround, the fireplace must be raised a minimum of 3 1/2" above the finished floor to accommodate the wall surround. (See next page)

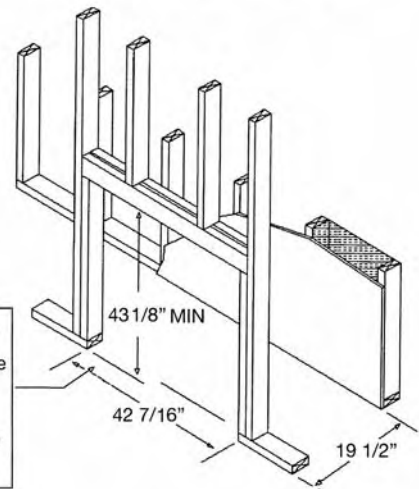

HB42 - Framing and Facing Requirements

HBZDV42 WITH HB42CVCK (CLEAN VIEW CIRCULATING KIT)

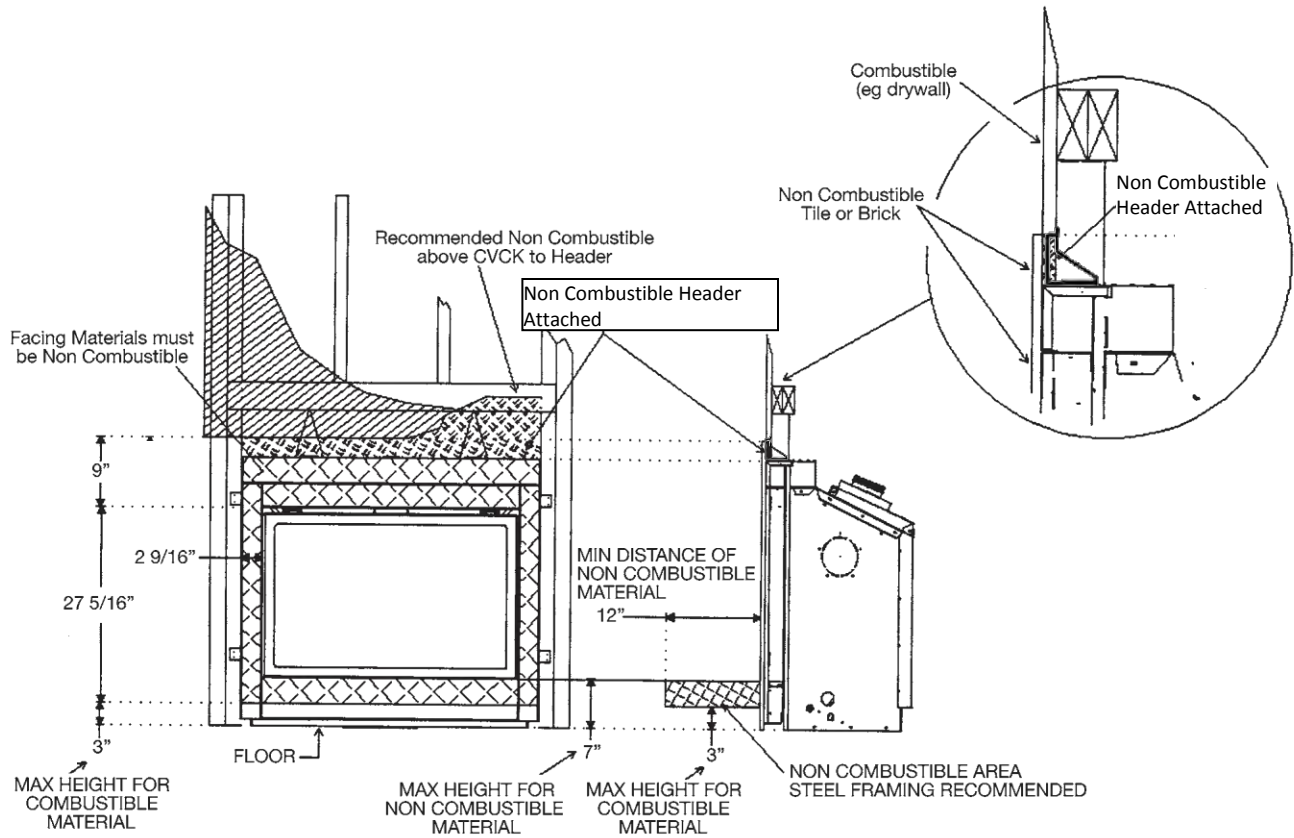

HB42CVCK WITH MQHB42SW SURROUND

*Note: A HBCVCK must be used when installing a MQHBSW Wall Surround.

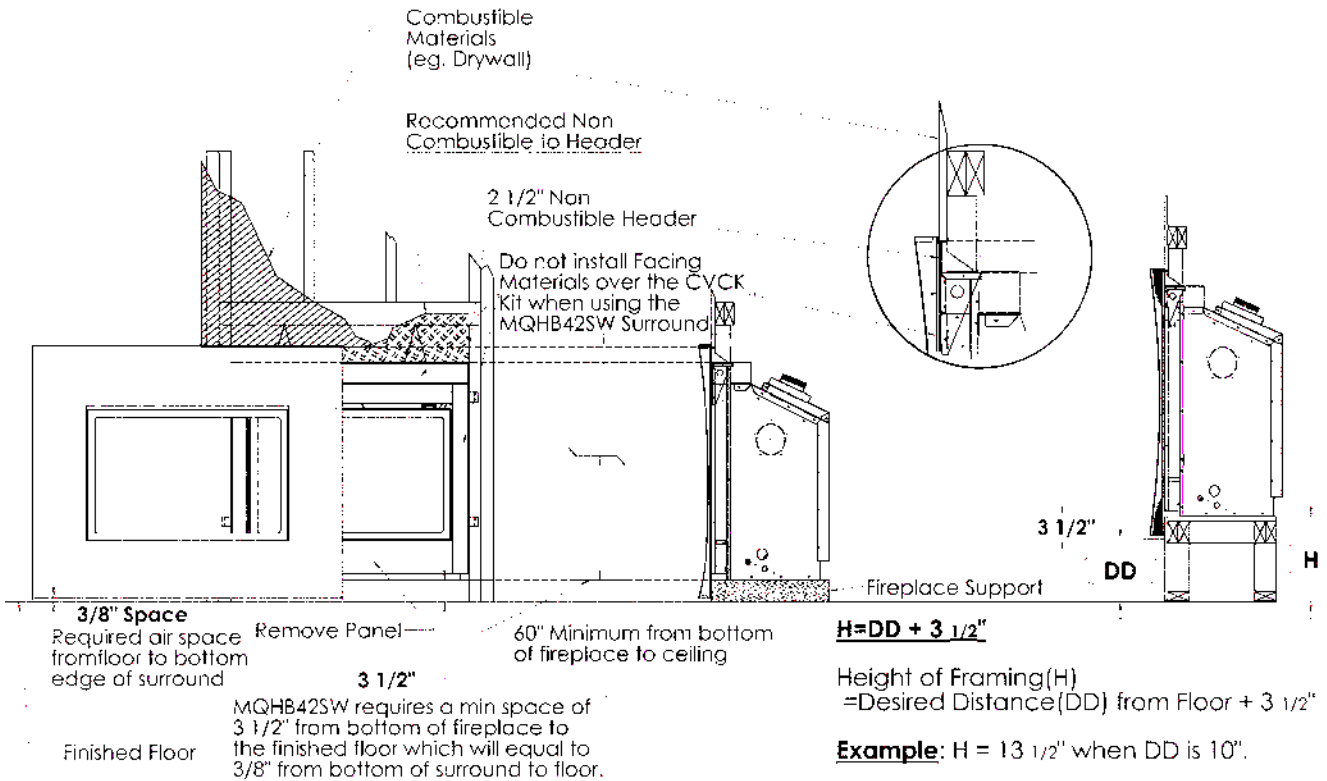

HB42 - HOW TO INSTALL CLEAN VIEW KIT (CVCK)

CAUTION: When using CVCK DO NOT INSTALL a Louver assembly.

1. Install optional fan kit (see Fan Instruction).
2. Fold two standoffs up into position and mount with supplied screws. (FIG 1)
3. Hang CVCK on top of fireplace retainer tabs and rotate down into position. (FIG 2)
4. Using the screws provided, fasten the non-combustible header onto the top of the CVCK assembly.
5. Using four supplied #6 screws, fasten CVCK kit to the inside frame of unit.
6. Kit is supplied with 2 valve extension knobs. Align the notches and slide the extensions onto valve knobs.
7. DO NOT brick or tile beyond the inside area of the CVCK kit to allow for removal of door.
8. Install optional pull screen system: First slide curtain onto rods and slide round end of rod into side post (REF A). Using 1/2" DT screws, mount the flattened end of rod to bottom side of rod hanger bracket (REF B). Repeat this step for opposite side.

NOTE: ADDITIONAL ACCESS FOR GASLINE INSTALLATION AND FAN ELECTRICAL INSTALLATION! When CVCK is installed in framing, remove 2 screws from the right and left side of the bottom panel (REF C). Once screws are removed, bottom panel can be rotated forward for access to gas valve and fan system.

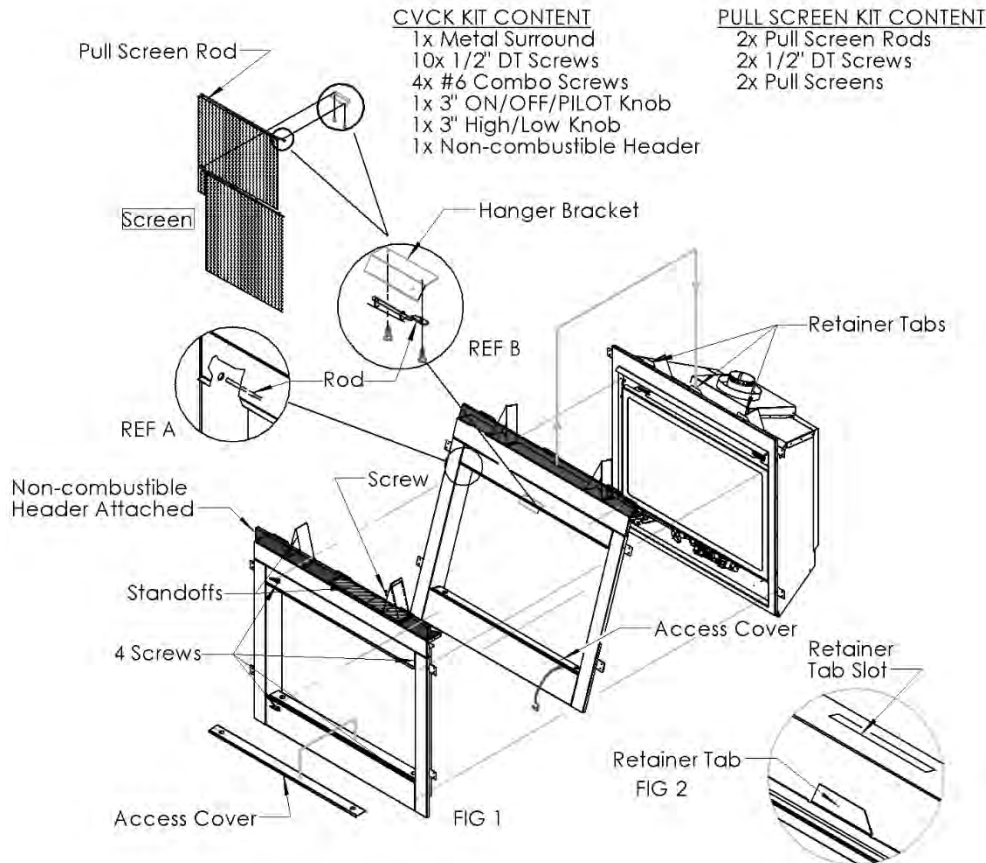

WARNING: Failure to position the parts in accordance with these diagrams or failure to use only parts specifically approved with this appliance may result in property damage or personal injury.

NOTE: When using the Clean View Kit (CVCK) and installing optional electrical components (i.e. Remote Controls, variable speed control, and or fan modules) locate them in the Clean View access area, unless other shielding devices like our IPI Component box is used.

Clearance to Combustibles

Clearance to Combustibles

Back (from Standoffs)	0 inches/0 mm
Side (from standoffs)	0 inches/0 mm
Floor	0 inches/0 mm
Ceiling (from bottom of fireplace)	60 inches/150 cm
Top (from standoffs)	0 inches/0 mm
Top of 90 degree bend in Minimum Enclosure of 45 to 46 inches	5 inches/128 mm/ All Vent Systems
Top of 90 degree bend in Enclosure over 46 inches	2 1/2 inches/64 mm / All Vent Systems
Top of Horizontal Pipe	1 1/2 inches/38 mm / All Vent Systems
Side & Bottom of Horizontal Pipe	1 inch/25.5mm / All Vent Systems
Vertical Vent Pipe	1 inch/25.5mm / Kingsman Vent Systems
Vertical Vent Pipe	1 1/4 inch/32mm / Simpson/AmeriVent/Selkirk Direct Temp Systems

(NOTE -Floor) if installing the appliance directly on carpeting or other combustible materials other than wood flooring, the appliance shall be installed on a metal or wood panel, the full width and depth of the appliance. Carpet may extend 1 inch above the floor of appliance.
For units with CVCK (Clean View Circulating Kit) see framing with CVCK to establish floor heights

MQHBZDV4236/MQRB4236 Parts List

Fireplace Part Numbers

MQHBZDV4236N (Millivolt) Fireplace Heater Rated NB, Ceramic

MQHBZDV4236NE(IPI) Glass 30,500 BTU at 75% efficient.

MQHBZDV4236LP (Millivolt) Fireplace Heater Rated LP, Ceramic

MQHBZDV4236LPE(IPI) Glass 29,200 BTU at 75% efficient.

MQRB4236NT (Millivolt) Fireplace Decorative, Tempered

MQRB4236NTE (IPI) Natural Gas, 24,000 BTU

MQRB4236LPT (Millivolt) Fireplace Decorative, Tempered,

MQRB4236LPTE (IPI) Propane, 24,000 BTU

MQRB4236N (Millivolt) Fireplace Heater Rated Ceramic,

MQRB4236NE (IPI) Natural Gas, 30,500 BTU

FIREPLACE REQUIREMENTS

Grills or CVCK (clean view circulating kit)

(Required for each unit)

HB42CVCK	CVCK(clean view circulating kit) no grill required
HB42GBA	Grill Kit - Classic Builder Antique Brass
HB42GBC	Grill Kit - Classic Builder Chrome
HB42GBP	Grill Kit - Classic Builder Polish Brass
HB42GBL	Grill Kit - Black
HB42PBL	Panel Grill Kit - Black

LOG SETS/ROCK/GLASS KITS:

(Required for each unit)

LOGF36	Log Set - 7 pce. - Fibre Split
MQROCK2	Rock Set Natural (HBZDV/MQRB)
MQROCK3	Rock Set Multi-Color (HBZDV/MQRB)
MQRSP2	Rock Platform, Support and 4 Screws (MQHBZDV3636, MQHBZDV4236)
MQEMBER	Glowing Embers, 2 ea. (MQRB4236) optional
MQRBD1	Driftwood/Rocks, 4 ea. (MQRB4236) Optional
MQSTONE	Decorative Stones
MQG5W	Decorative Glass 1/2" White 5 lbs
MQG5A	Decorative Ember Glass – Azuria Blue - 5 lbs
MQG5C	Decorative Ember Glass - Copper - 5 lbs
MQG5B	Decorative Ember Glass - Black - 5 lbs
ULK2	Universal Light Kit (MQRB4236)

Fireplace Wall Mount Finishing Surround for

HB42CVCK Kits

MQHB42SWCCBL	Surround Concave Black (Coverage 42 3/4" H x 55 7/16" W)
MQHB42SWCCPW	Surround Concave Pewter (Coverage 42 3/4" H x 55 7/16" W)
MQHB42SWCVBL	Surround Convex Black (Coverage 42 15/16" H x 44 5/16" W)
MQHB42SWCVPW	Surround Convex Pewter (Coverage 42 15/16" H x 44 5/16" W)

Fireplace Surrounds - Trims

HB42SAB	Surround - Antique Brass (Coverage 37 5/8" H x 45 1/8" W)
HB42SBL	Surround - Black (Coverage 37 5/8" H x 45 1/8" W)
HB42SCR	Surround - Chrome (Coverage 37 5/8" H x 45 1/8" W)
HB42SPB	Surround - Polish Brass (Coverage 37 5/8" H x 45 1/8" W)
HB42SLAB	Surround Slim Line - Antique Brass (Coverage 37 3/8" H x 43 3/8" W)

HB42SLCR	Surround Slim Line - Chrome (Coverage 37 3/8" H x 43 3/8" W)
HB42SLPB	Surround Slim Line - Polish Brass (Coverage 37 3/8" H x 43 3/8" W)
HB42SLBL	Surround Slim Line - Gun Metal Black (Coverage 37 3/8" H x 43 3/8" W)

Designer Doors for 42" Fireplaces - Operative

HB42DDA1BL	Designer Door Arch - Series 1 - Black
HB42DDTA1A	Trim - Antique for Designer Arch - Series 1
HB42DDTA1C	Trim - Chrome for Designer Arch - Series 1
HB42DDTA1P	Trim - Polish Brass for Designer Arch - Series 1
HB42DDS1BL	Designer Door Straight - Series 1 - Black
HB42DDTS1A	Trim - Antique for Designer Straight - Series 1
HB42DDTS1C	Trim - Chrome for Designer Straight - Series 1
HB42DDTS1P	Trim - Polish for Designer Straight - Series 1

HB42CSS Safety Screen Replacement

HB42PSK Pull Screen Kit for CVCK

Overlays

HB42ADTH	Arch Door Frame - Top Half Black
HB42ADDX	Arch Door Frame - Deluxe Black
HB42ADDA	Arch Door Frame - Double Arch Black
HB42ADDD	Arch Door Frame - Double Door Arch Black

Accessories

*In the U.S.A. Thermostats are not permitted for Vented Gas Fireplaces (ANSI Z21.50b)

Z36FK Fan Kit w/Variable Speed Wall Mount Control
(Temperature Sensing)

Z1MT Thermostat Millivolt Wall Mount

Z80PT Thermostat Programmable Digital Millivolt
Wall Mount (1F80-40)

DCHS Remote Control Heatshield

VLBIT4 Log Bits - Large Four Piece Kit

VLBIT6 Log Bits - Small Six Piece Kit

Refractory Liner

HB42PL	Porcelain Reflective Liner (all HB42 models)
HB42RLC	Refractory Liner Classic (all HB42 models)
MQRB42PL	Porcelain Liner (3 pce.) for MQRB4236
HB42RLT	Refractory Liner Traditional (all HB42 models)
HB42RLH	Refractory Liner Herring Bone (all HB42 models)

Replacement Burner Assembly

4236MQ-BNGSI	Burner Assembly - Natural Gas c/w Valve System (MQHBZDV4236N)
4236RB-BNGSI	Burner Assembly - Natural Gas c/w Valve System (MQRB4236)
4236MQ-BLPSI	Burner Assembly - Liquid Propane c/w Valve System (MQHBZDV4236LP)
4236RBT-BNGSI	Burner Assembly - Natural Gas c/w Valve System (MQRB4236NT)
4236RBT-BLPSI	Burner Assembly - Liquid Propane c/w Valve System (MQRB4236LPT)

Conversion Kit (Sit Valve Only)

4232HB-CKLP LP	Conversion Kit for MQHBZDV4236 (Millivolt)
4232HB-CKLPI LP	Conversion Kit for MQHBZDV4236 (IPI)
4232HB-CKNG NG	Conversion Kit for MQHBZDV4236 (Millivolt)
4232HB-CKNGI NG	Conversion Kit for MQHBZDV4236 (IPI)
4236RB-CKNG NG	Conversion Kit for MQRB4236 (Millivolt)
4236RB-CKNGI NG	Conversion Kit for MQRB4236 (IPI)
4236RBT-CKNG NG	Conversion Kit for MQRB4236T (Millivolt)
4236RBT-CKNGI NG	Conversion Kit for MQRB4236T (IPI)
4236RBT-CKLP LP*	Conversion Kit for MQRB4236T (Millivolt)
4236RBT-CKLPI*	Conversion Kit for MQRB4236T (IPI)

4236RB-SRKP* Upgrade Kit

***NOTE: THE MQRB4236N CANNOT BE CONVERTED TO LP.**

If the **MQRB4236NT** you wish to convert to LP has a serial number less than **#4708**

You MUST order the 4236RB-SRKP upgrade kit.

Valve System Parts - New Top convertible SIT (Millivolt)

1000-P136WR	Thermopile GOAI-524
1001-P069SI	Electrode Sparker 915.069 TC SIT
1001-P216SI	Thermocouple 290.216 TC SIT
1001-P165SI	Orifice Pilot NG 977.165 TC SIT
1001-P167SI	Orifice Pilot LP 977.167 TC SIT
1001-P633SI	Valve Nova LP Hi/Lo 0820651
1001-P634SI	Valve Nova NG Hi/Lo 0820652
1001-P713SI	Pilot Burner LP 199.713 TC SIT
1001-P714SI	Pilot Burner NG 199.714 TC SIT

Remote Control / Millivolt

GFRC	-Remote Control Millivolt / IPI – On/Off
GTRC	-Remote Control Millivolt - Thermostat
GTMRCN	-Remote Control Millivolt – Thermostat/Modulating - NG
GTMRCP	-Remote Control Millivolt – Thermostat/Modulating - LP
GTFRCN	-Remote Control Millivolt – Thermostat/Modulating/Fan (NG)
GTFRCP	-Remote Control Millivolt – Thermostat/Modulating/Fan (LP)

Electronic Ignition/Remote Control IPI

*In the U.S.A. Thermostats are not permitted for Vented Gas Fireplaces (ANSI Z21.50b)

EGTRC	Remote Control IPI (Thermostat)
EGTMRCN	Remote Control IPI (Thermostat/Modulating - NG)
EGTMRCP	Remote Control IPI (Thermostat/Modulating - LP)
EGTFRCN	Remote Control IPI (Thermostat/Modulating/Fan - NG)
EGTFRCP	Remote Control IPI (Thermostat/Modulating/Fan - LP)

Electronic Ignition Replacement Parts IPI

1002-P001si	Valve IPI (NG; ON/OFF)
1002-P002si	Valve IPI (LP; ON/OFF)
1006-P002si	Valve IPI (NG; Hi/Lo)
1006-P603si	Valve IPI (LP; Hi/Lo)
1002-P047si	Pilot Assembly (LP)
1002-P033si	Pilot Assembly (NG)
1002-P089si	Spark Electrode (Long)
1002-P113si	Electrode Flame Sensor (Long)
1002-P302si	IPI Ignition Board
1002-P850si	AC Wall Adapter
1002-P12BH	Battery Pack
1002-P912si	Wiring Harness
1002-P166si	Orifice Pilot (NG #62)
1002-P168si	Orifice Pilot (LP #35)
1002-P013si	Stepper Motor (NG)
1002-P012si	Stepper Motor (LP)
1002-P016is	Hi/Lo Regulator (NG)
1002-P014si	Hi/Lo Regulator (LP)

Miscellaneous Parts

1000-150GE	#Silicone GE Red IS806 #736
1000-150MP	#Hi-Temp Mill Pac Sealant 840099
1000-214	#Piezo-Igniter 1244-17 MARK 21
1000-215	#Pal Nut (18MMX1.5MM)BLK (1364.03)
1000-218	#Switch Ivory (1451/001)
1000-227	#Cover Ivory (86001/001)
1000-255	#Orifice Brass - (State Size)
1000-EMBER	#Moon Rock
2000-080	#Thermodisc 2450 (For Blower)
2000-081	#Blower Motor QLN65/2400
1000-085	#Control Variable Speed KBWC-13BV

1000-306	Thermalcord - Adhesive Back for Door Frame
42HB-310	Ceramic Glass
36HB-123	Upper Door Spring
OFP42SA	Spark Assist

Kingsman Fireplace Venting

Number	Description
ZDVHSK	Horizontal Vent Starter Kit - 3 FT Length Horizontal Vent Termination, Wall Thimble, 36" Flex Pipe, Mill Pac, screws/washers, springs.
ZDVHSK5	Horizontal Vent Starter Kit - 5 FT Length Horizontal Vent Termination, Wall Thimble, 60" Flex Pipe, Mill Pac, screws/washers, springs.
FDVVT40	Vertical Vent Termination converts from 15'-40' to 15' and under
FDVHT	Horizontal Vent Termination
FDVHSQ	Horizontal Square Termination
ZDVST	Horizontal Snorkel Termination (34" Tall, 24" Center to Center)
FDVHSC	Safety Cage for Horizontal Termination
ZDVAIS	Attic Insulation Shield
ZDVVOS	Offset Support
ZDVFS	Firestop Spacer
ZDVRS	Roof Support
ZDVWT	Wall Thimble (Horizontal Venting)
ZDVSSLR	Siding Shield - Large Return
ZDV48GP	Galvanized Pipe 7" Dia. x 48" (Vertical Installations)
ZDVAAF	Flashing 7" c/w Storm Collar (1/12 to 7/12)
ZDVAF2	Flashing 7" c/w Storm Collar (8/12 to 12/12)
ZDVAF3	Flashing 7" c/w Storm Collar Flat
ZDV7SC	Storm Collar 7"
ZDVFK5	Flex Kit (4" & 7" Dia.) x 2.5' (Unexpanded) 5' Expanded
ZDVFK8	Flex Kit (4" & 7" Dia.) x 4' (Unexpanded) 8' Expanded
ZDVFK20	Flex Kit (4" & 7" Dia.) x 10' (Unexpanded) 20' Expanded
ZDV4FC	*Kits are complete with spring stand-offs, silicone. Flex Connector 4" Diameter
ZDV7FC	Flex Connector 7" Diameter
ZDV4SS	Spring 4" Standoff Spacer
ZDVDFSA	Simpson Dura-Vent Fireplace Adapter (for ZDV33/36/42/47, ZDV6000, MDV31 & HB models)
ZDVHKSQ	Horizontal Square Termination Vent Starter Kit - 3 FT Length Horizontal Vent Termination, Wall Thimble, Wall Thimble, 36" Flex Pipe, Mill Pac
ZDVHKSQ5	Horizontal Square Termination Vent Starter Kit - 5 FT Length Horizontal Vent Termination, Wall Thimble, Wall Thimble, 60" Flex Pipe, Mill Pac
FDVHSQ	Horizontal Square Vent Termination

Locating Your Appliance

LOCATION KEY:

- A. Flat on Wall
- B. Across the Corner
- C. As an Island
- D. As a Room Divider
- E. Flat on Wall Corner
- F. Exterior Wall

See Mantel Leg Clearances Instruction for the proper placement of fireplace.

Island installation with a top vent is possible as long as the horizontal portion of the vent system does not exceed 20 feet (6.1 m).

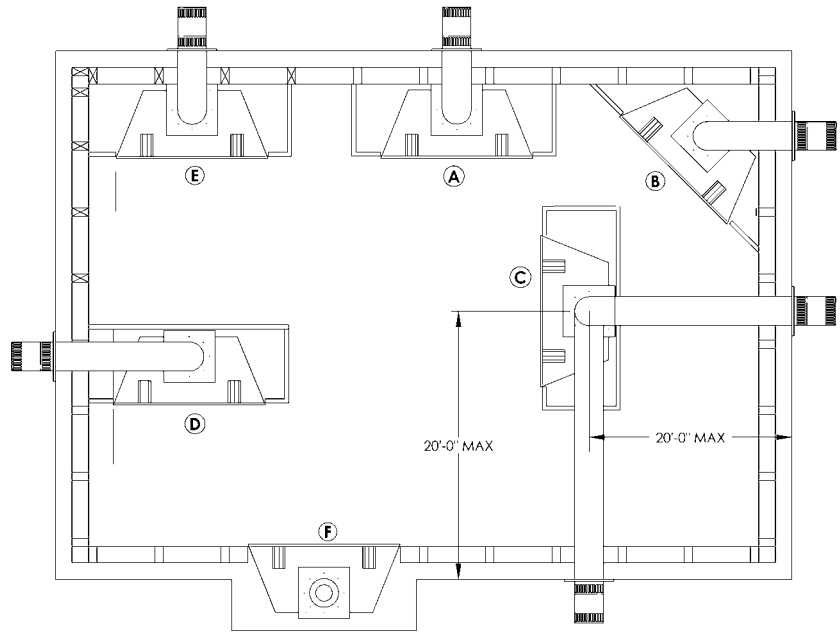

Fireplace Dimensions

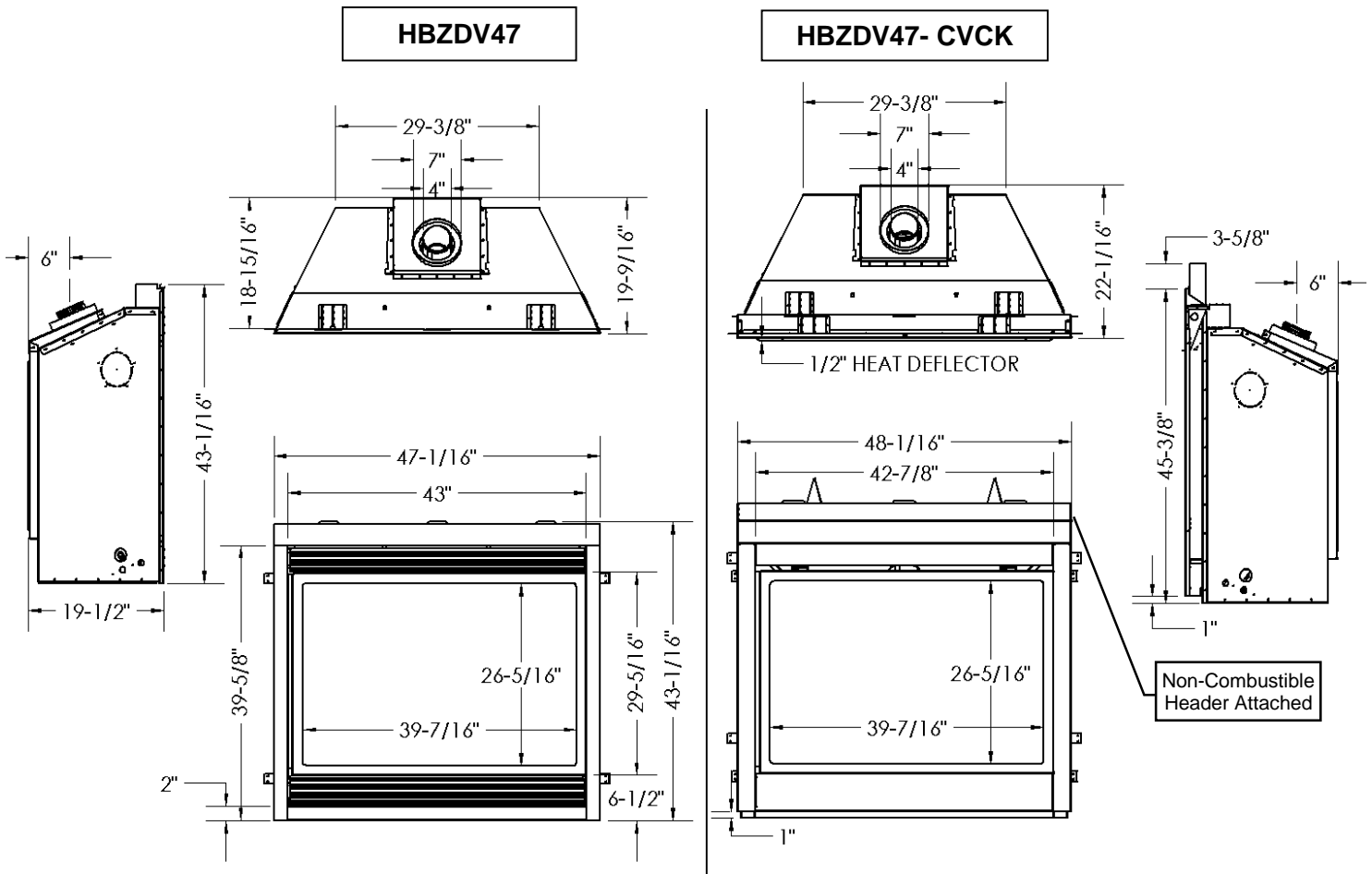

MQHBZDV4736 - Framing for your Gas Fireplace

Framing Specifications

1. Cold climate installation recommendation: When installing this fireplace against non insulated exterior wall or chase, it is recommended that the outer walls be insulated to conform to applicable insulation codes. Drywall must be installed over insulation to prevent contact of insulation and unit.
2. Choose fireplace location and frame in accordance with the fireplace framing dimensions specified (See Framing Diagrams). Bend nailing tabs forward on left and right of unit and place fireplace into framed enclosure. This allows for 1/2" in front of framing tabs for finishing materials.
3. Drywall or other material can extend flush with the appliance on the bottom, sides and top of fireplace. (louvered models only)
4. When installing horizontal with a 90 degree bend maintain a minimum of two and a half (2.5") inches above the bend in enclosures, insulation

sleeve is required. If greater than six and a half (6.5") an insulation sleeve is not required.

5. For a fireplace with louvers combustible floor can raise 1" above the bottom of the fireplace. For a fireplace with HB47CVCK (Clean view Circulating Kit) floor or hearth can raise 7" above the bottom of the fireplace with portions being combustible and non combustible. See drawing on following page.
6. When installing MQHB47SWCC wall surround, the fireplace must be raised a minimum of 3 1/2" above the finished floor, to accommodate the wall surround. When installing MQHB47SWCV wall surround the fireplace must be raised 2 3/4" above the finished floor. The fireplace may be raised higher but the 60" clearance measured from the bottom of the fireplace to the ceiling must be maintained at all times. (i.e. For an 8 ft. ceiling the unit can be raised only 36 inches.)

It is recommended for **Propane Horizontal Installations** that the venting should be a minimum of one foot vertical off the flue before the elbow on any horizontal runs of one foot or greater. This allows for cleaner combustion and greatly reduces carboning and cleaning of glass. (Does not apply to Back Flue Models).

HBZDV47 Louvered

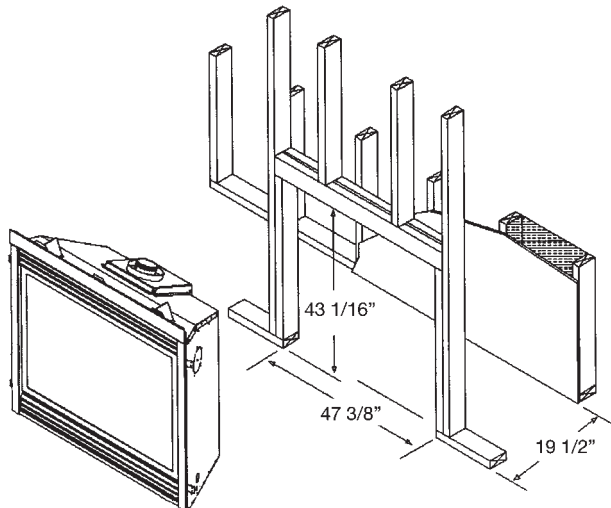
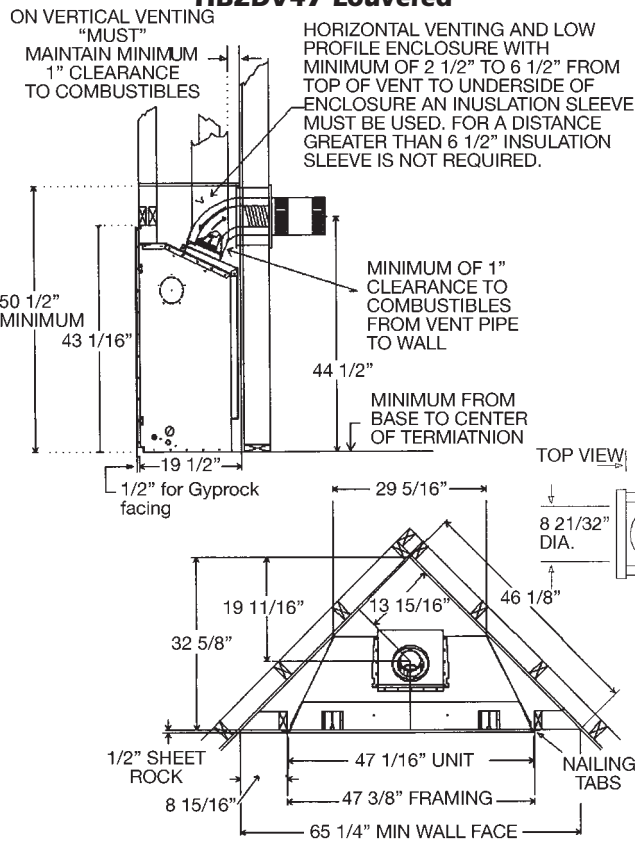

HBZDV47 WITH HB47CVCK (CLEAN VIEW CIRCULATING KIT)

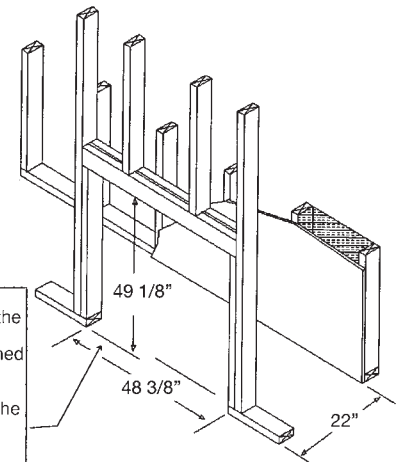
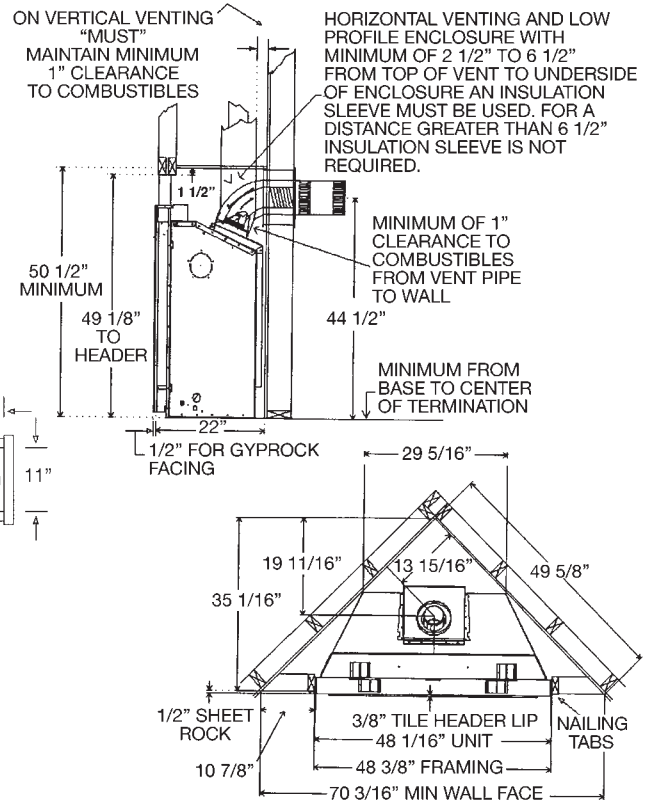

NOTE: When installing MQHB47SWCC wall surround the fireplace must be raised a minimum 3 1/2" above the finished floor to accommodate the wall surround. When installing MQHB47SWCV wall surround the fireplace must be raised 2 3/4" above the finished floor. (See next page)

Framing and Facing Requirements

HBZDV47 WITH HB47CVCK (CLEAN VIEW CIRCULATING KIT)

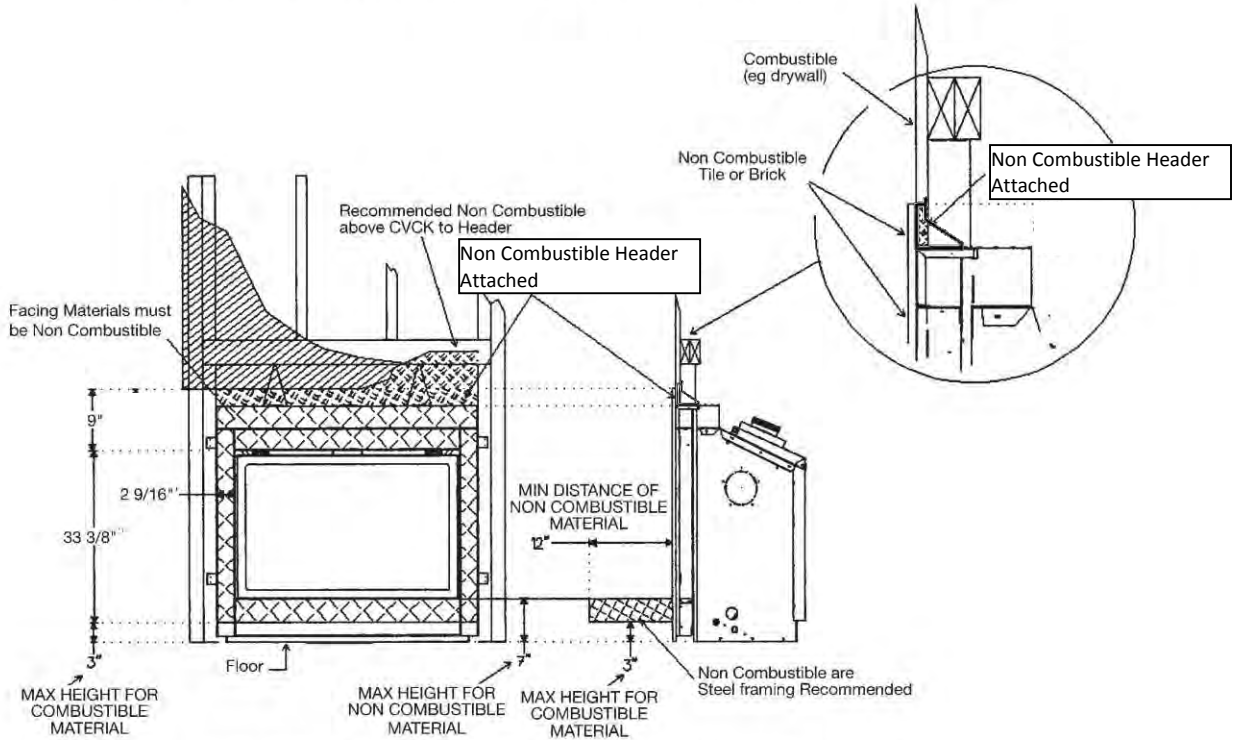

HB47CVCK WITH MQHB47SW WALL SURROUND

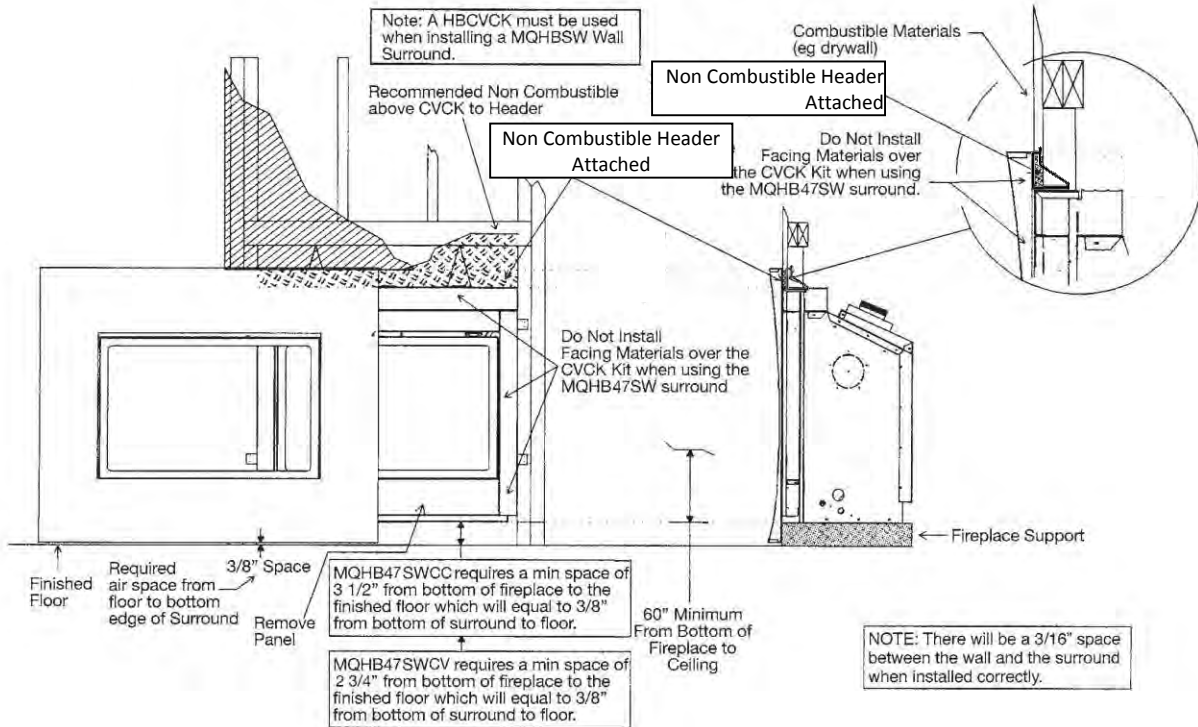

HB47 - HOW TO INSTALL CLEAN VIEW KIT (CVCK)

CAUTION: When using CVCK DO NOT INSTALL a Louver assembly.

1. Install optional fan kit (see Fan Instruction).
2. Fold two standoffs up into position and mount with supplied screws. (FIG 1)
3. Hang CVCK on top of fireplace retainer tabs and rotate down into position. (FIG 2)
4. Using the screws provided, fasten the non-combustible header onto the top of the CVCK assembly.
5. Using four supplied #6 screws, fasten CVCK kit to the inside frame of unit.
6. Kit is supplied with 2 valve extension knobs. Align the notches and slide the extensions onto valve knobs.
7. DO NOT brick or tile beyond the inside area of the CVCK kit to allow for removal of door.
8. Install optional pull screen system: First slide curtain onto rods and slide round end of rod into side post (REF A). Using 1/2" DT screws, mount the flattened end of rod to bottom side of rod hanger bracket (REF B). Repeat this step for opposite side.

NOTE: ADDITIONAL ACCESS FOR GASLINE INSTALLATION AND FAN ELECTRICAL INSTALLATION! When CVCK is installed in framing, remove 2 screws from the right and left side of the bottom panel (REF C). Once screws are removed, bottom panel can be rotated forward for access to gas valve and fan system.

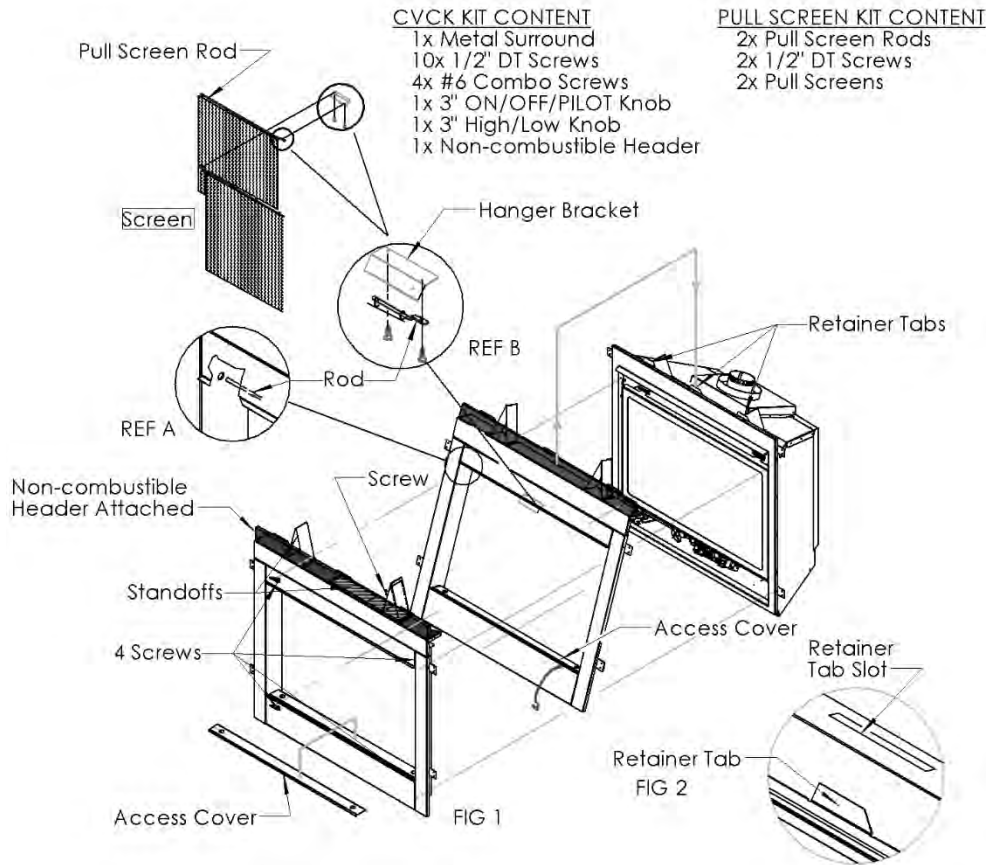

WARNING: Failure to position the parts in accordance with these diagrams or failure to use only parts specifically approved with this appliance may result in property damage or personal injury.

NOTE: When using the Clean View Kit (CVCK) and installing optional electrical components (i.e. Remote Controls, variable speed control, and or fan modules) locate them in the Clean View access area, unless other shielding devices like our IPI Component box is used.

Clearance to Combustibles

Clearance to Combustibles

Back (from Standoffs)	0 inches/0 mm
Side (from standoffs)	0 inches/0 mm
Floor	0 inches/0 mm
Ceiling (from bottom of fireplace)	60 inches/150 cm
Top (from standoffs)	0 inches/0 mm
Top of 90 degree bend in Minimum Enclosure of 50 1/2 to 56 1/2 inches	with insulation sleeve 2 1/2 inches/64 mm / All Vent Systems
Top of 90 degree bend in Enclosure over 56 1/2 to 60 inches	without insulation sleeve 4 1/2 inches/114.75 mm / All Vent Systems
Top of 90 degree bend in Enclosure over 60 inches	without insulation sleeve 2 1/2 inches/64 mm / All Vent Systems
Side & Bottom of Horizontal Pipe	1 inch/25.5mm / All Vent Systems
Vertical Vent Pipe	1 inch/25.5mm / Kingsman Vent Systems
Vertical Vent Pipe	1 1/4 inch/32mm / Simpson/AmeriVent/Selkirk Direct Temp Systems

(NOTE -Floor) if installing the appliance directly on carpeting or other combustible materials other than wood flooring, the appliance shall be installed on a metal or wood panel, the full width and depth of the appliance. Carpet may extend 1 inch above the floor of appliance.
For units with CVCK (Clean View Circulating Kit) see framing with CVCK to establish floor heights

HBZDV4736 - Parts List

ZERO CLEARANCE DIRECT VENT GAS FIREPLACES 47" WIDE

Listed for USA / Canada, Dual Burner, Millivolt SIT Valve with Hi/Lo Adjustment, Wall Switch, Tempered Glass, Safety Screen, Four / Seven Sloped Flue

FIREPLACE PART NUMBERS

HBZDV4736N	Fireplace Decorative Rated NG, (Millivolt) Tempered Glass, 40,000 BTU
HBZDV4736NE	Fireplace Decorative Rated NG, (IPI) Tempered Glass, 40,000 BTU
HBZDV4736LP	Fireplace Decorative Rated LP, (Millivolt) Tempered Glass, 36,000 BTU
HBZDV4736LPE	Fireplace Decorative Rated LP, (IPI) Tempered Glass, 36,000 BTU

FIREPLACE REQUIREMENTS

GRILLS OR CVCK (CLEAN VIEW CIRCULATING KIT) (REQUIRED FOR EACH UNIT)

HB47CVCK	CVCK(clean view circulating kit) no grill required
HB47GBL	Panel Grill Kit - Black

LOG SET (REQUIRED FOR EACH UNIT)

LOGF36	Log Set - 7 pc. - Fiber Split Oak
--------	-----------------------------------

OPTIONAL BRICK OR PORCELAIN LINERS

HB47PL	Porcelain Reflective Liner
HB47RLT	Refractory Liner Traditional
HB47RLH	Refractory Liner Herring Bone
HB47RRH	Refractory Liner Red Herring Bone

ACCESSORIES

HB47CSS	Safety Screen Replacement
Z36FK	Fan Kit w/Variable Speed Wall Mount Control (Temperature Sensing)
VLBIT4	Log Bits - Large Four Piece Kit
VLBIT6	Log Bits - Small Six Piece Kit

REPLACEMENT BURNER ASSEMBLY

4736HB-BNGSI	Burner Assembly - Natural Gas c/w Valve System (HBZDV4736N, HBZDV4736NE)
4736HB -BLPSI	Burner Assembly - Propane c/w Valve System (HBZDV4736LP, HBZDV4736LPE)

CONVERSION KITS

4740HB-CKLP	LP Conversion Kit for HBZDV4740, HBZDV4736 (Millivolt)
4740HB-CKNG	NG Conversion Kit for HBZDV4740, HBZDV4736 (Millivolt)
4740HB-CKLPI	LP Conversion Kit for HBZDV4740, HBZDV4736 (IPI)
4740HB-CKNGI	NG Conversion Kit for HBZDV4740, HBZDV4736 (IPI)

OPTIONAL THERMOSTATS AND REMOTE CONTROLS

*In the U.S.A. Thermostats are not permitted for Vented Gas Fireplaces (ANSI Z21.50b)

Z2MT	Thermostat Digital – Vertical Wall Mount - MV/PF1
Z80PT	Thermostat Programmable Digital – Wall Mount – MV/PF1
GFRC	Remote Control Millivolt / IPI – On/Off
GTRC	Remote Control Millivolt - Thermostat
GTMRCN	Remote Control Millivolt – Thermostat/Modulating - NG
GTMRCP	Remote Control Millivolt – Thermostat/Modulating - LP
GTFRCN	Remote Control Millivolt – Thermostat/Modulating/Fan - NG
GTFRCP	Remote Control Millivolt – Thermostat/Modulating/Fan - LP

ELECTRONIC IGNITION/REMOTE CONTROL IPI

EGTRC	Remote Control IPI (Thermostat)
EGTMRCN	Remote Control IPI (Thermostat/Modulating - NG)
EGTMRCP	Remote Control IPI (Thermostat/Modulating - LP)
EGTFRCN	Remote Control IPI (Thermostat/Modulating/Fan - NG)
EGTFRCP	Remote Control IPI (Thermostat/Modulating/Fan - LP)

ELECTRONIC IGNITION REPLACEMENT PARTS IPI

1006-P002si	Valve IPI (NG; Hi/Lo)
1006-P003si	Valve IPI (LP; Hi/Lo)
1002-P047si	Pilot Assembly (LP)
1002-P033si	Pilot Assembly (NG)
1002-P089si	Spark Electrode (Long)
1002-P113si	Electrode Flame Sensor (Long)
1002-P302si	IPI Ignition Board
1002-P850si	AC Wall Adapter
1002-P12BH	Battery Pack
1002-P912si	Wiring Harness
1001-P166si	Orifice Pilot (NG)
1001-P168si	Orifice Pilot (LP)
1002-P013si	Stepper Motor (NG)
1002-P012si	Stepper Motor (LP)
1002-P016si	Hi/Lo Regulator (NG)
1002-P014si	Hi/Lo Regulator (LP)

VALVE SYSTEM PARTS / MILLIVOLT

1000-P136WR	Generator / Thermopile
1001-P069SI	Electrode Sparker 915.069 TC SIT
1001-P216SI	Thermocouple 290.216 TC SIT
1001-P165SI	Orifice Pilot NG 977.165 TC SIT
1001-P167SI	Orifice Pilot LP 977.167 TC SIT
1001-P280SI	Tubing 24"
1001-P633SI	Valve Nova LP Hi/Lo 0820651
1001-P634SI	Valve Nova NG Hi/Lo 0820652
1001-P713SI	Pilot Burner LP 199.713 TC SIT
1001-P714SI	Pilot Burner NG 199.714 TC SIT

MISCELLANEOUS PARTS

1000-150GE	Silicone GE Red IS806 #736
1000-150MP	Hi-Temp Millpac Sealant 840099

1000-214	Piezo-Igniter 1244-17 MARK 21
1000-215	Pal Nut (18MMX1.5MM)BLK (1364.03)
1000-218	Switch Ivory (1451/001)
1000-227	Cover Ivory (86001/001)
1000-255	Orifice Brass - (State Size)
2000-080	Thermodisc 2450 (For Blower)
1000-306	Thermalcord - Adhesive Back for Door Frame
1000-085	Control Variable Speed KBWC-13BV
FP15GC	Stainless Steel Gas Connector

KINGSMAN FIREPLACE VENTING

ZDVHSK	Horizontal Vent Starter Kit - 3 FT Length Horizontal Vent Termination, Wall Thimble, 36" Flex Pipe, Mill Pac
ZDVHSK5	Horizontal Vent Starter Kit - 5 FT Length Horizontal Vent Termination, Wall Thimble, 60" Flex Pipe, Mill Pac
ZDVHSKSQ	Horizontal Square Termination Vent Starter Kit -3 FT Length Horizontal Vent Termination, Wall Thimble, Wall Thimble, 36" Flex Pipe, Mill Pac
ZDVHSKSQ5	Horizontal Square Termination Vent Starter Kit -5 FT Length Horizontal Vent Termination, Wall Thimble, Wall Thimble, 60" Flex Pipe, Mill Pac
Z47VT	Vertical Vent Termination
FDVHT	Horizontal Vent Termination
FDVHSQ	Horizontal Square Termination
Z47ST24	Horizontal Snorkel Termination (24" Tall, 14-1/2" Center to Center)
Z47ST36	Horizontal Snorkel Termination (36" Tall, 26-1/2" Center to Center)
Z57STSC	Safety Cage for Horizontal Snorkel Termination

FDVHSCU	Safety Cage for Horizontal Termination
ZDVAIS	Attic Insulation Shield
Z7AIS24	Attic Insulation Shield 24"
ZDVVOS	Offset Support
ZDVFS	Firestop Spacer
ZDVRS	Roof Support
ZDVWT	Wall Thimble (Horizontal Venting)
ZDVSS	Siding Shield for FDVHT
ZDVSSLR	Siding Shield - Large Return
ZDV48GP	Galvanized Pipe 7" Dia. x 48" (Vertical Installations)
ZDVAAF	Flashing 7" c/w Storm Collar (1/12 to 7/12)
ZDVAF2	Flashing 7" c/w Storm Collar (8/12 to 12/12)
ZDVAF3	Flashing 7" c/w Storm Collar Flat
ZDV7SC	Storm Collar 7"
ZDVFK5	Flex Kit (4" & 7" Dia.) x 2.5' (Unexpanded) 5' Expanded
ZDVFK8	Flex Kit (4" & 7" Dia.) x 4' (Unexpanded) 8' Expanded
ZDVFK20	Flex Kit (4" & 7" Dia.) x 10' (Unexpanded) 20' Expanded *Kits are complete with spring stand-offs & silicone.
ZDV4FC	Flex Connector 4" Diameter
ZDV7FC	Flex Connector 7" Diameter
ZDV4SS	Spring 4" Standoff Spacer

Clearances – HB36 / HB42 / HB47 – Mantels & Surrounds

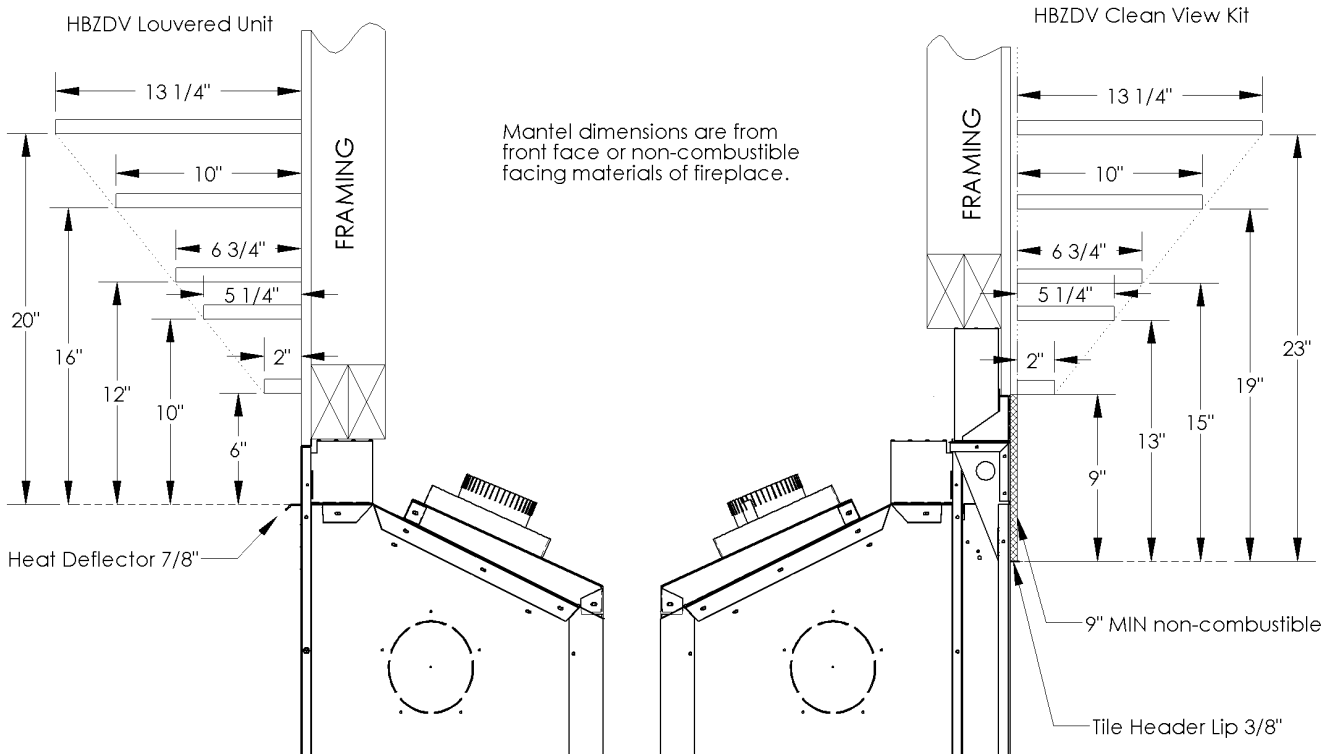

Warning: Combustible objects must not be placed on a non-combustible mantel unless the non-combustible mantel meets the minimum height and width requirements for a combustible mantel.

MQHBZDV Fireplace with Clean View Kit and MQHBSW Surround

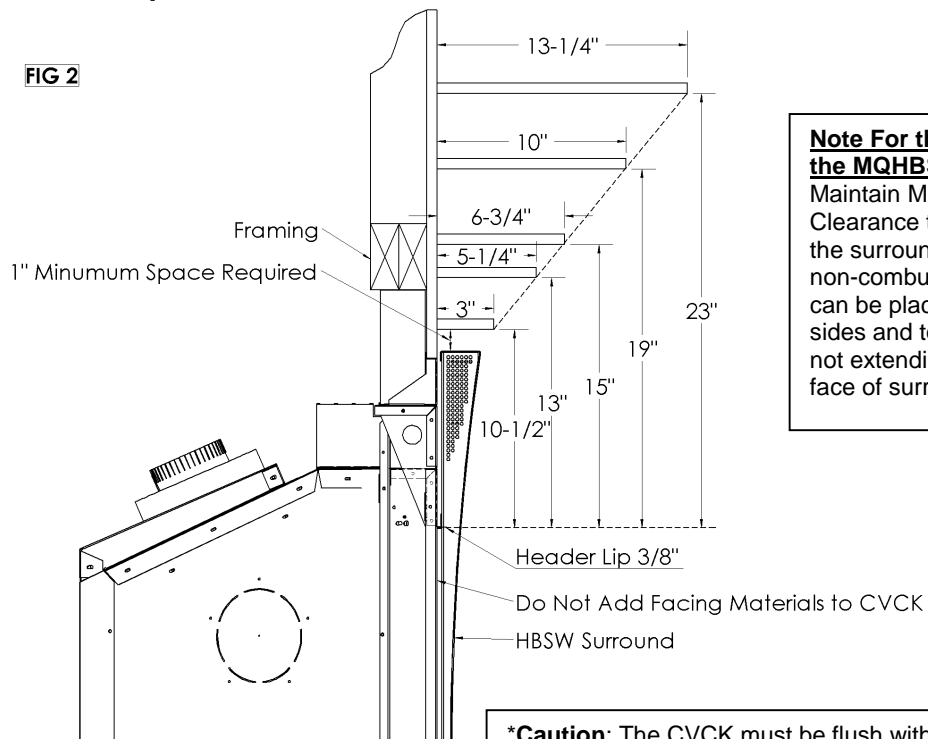

Mantel Leg Clearances

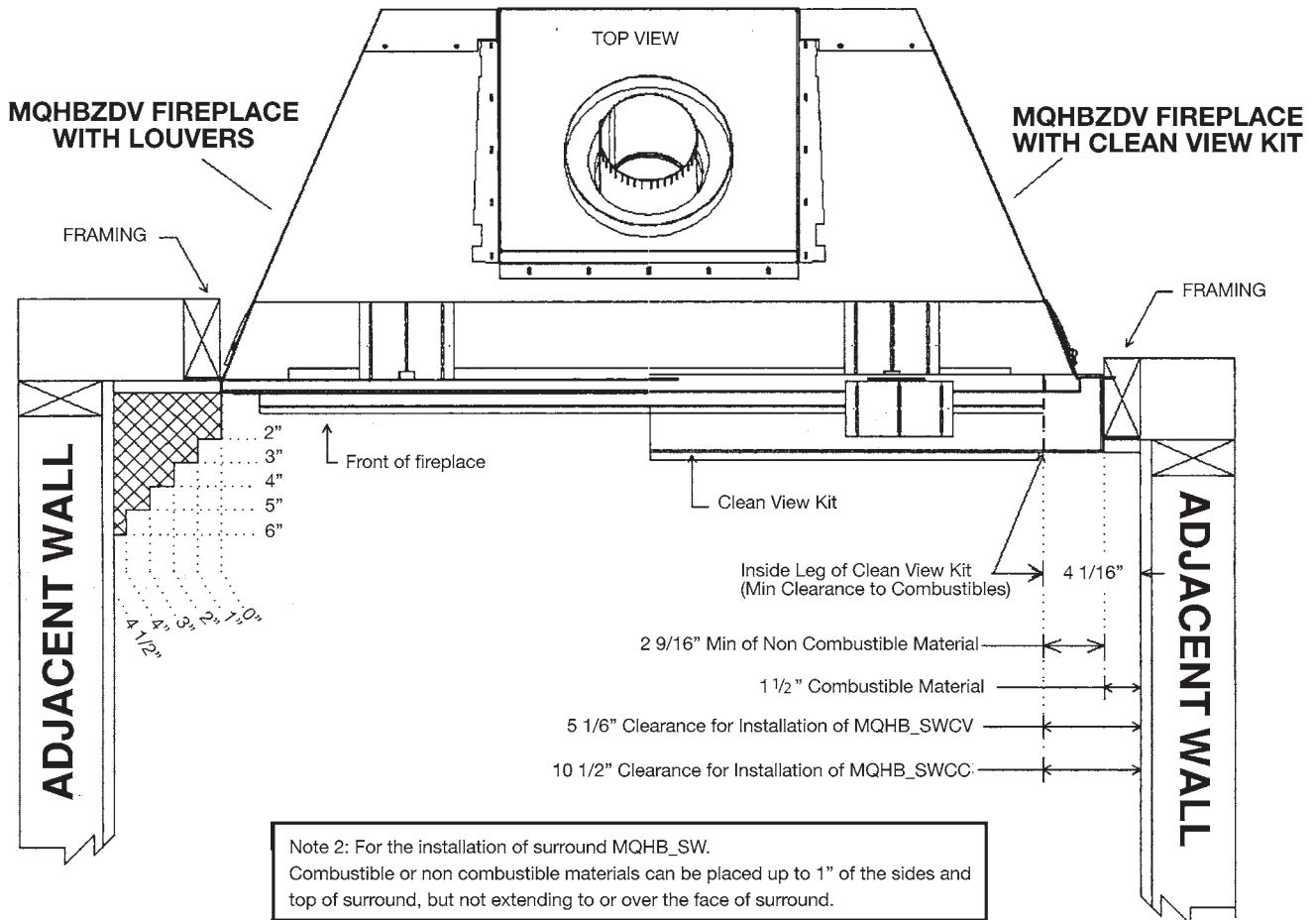

Mantels

Depending on the depth of the fireplace mantel, it may be installed higher or lower from the top of the fireplace opening. See drawings for proper installation height of your combustible mantel. Non-combustible mantels may be installed at any height above the fireplace opening except when using MQHBSW.

Non combustible materials such as brick, tile, etc. can extend up to or over the front face of the fireplace (NO PORTION OF GRILL AREA OR DOOR AREAS CAN BE COVERED) except where designer clean view kit is used.

Combustible material can extend flush to unit up to the top, bottom and sides of fireplace to stand-offs.

For COMBUSTIBLE materials extending in front of fireplace consult (Mantel and Mantel Leg Drawings).

Surrounds

If installing wide or slim line surrounds, the finish materials must be flush with the front facing of the fireplace.

Note: When using paint or lacquer to finish the mantel, such paint or lacquer must be heat resistant (250°F) to prevent discoloration.

MOSW Wall Mount Surround Dimensions

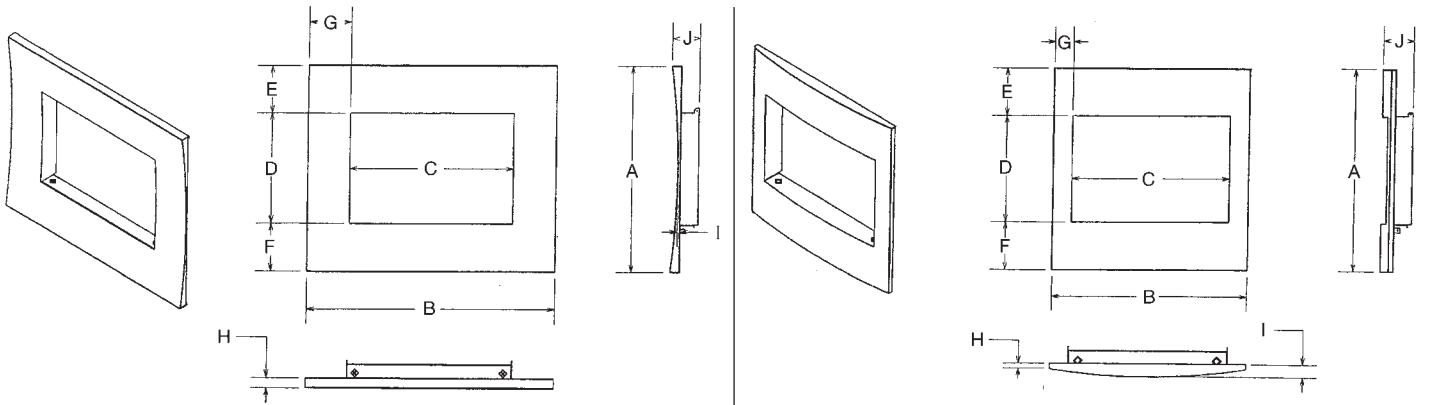

Concave	A	B	C	D	E	F	G	H	I	J	L
HB36	40 1/2	49 1/2	32 1/2	21 5/8	9 1/2	9 1/2	8 1/2	2 1/2	5 1/2	32 7/16	
HB42	42 3/4	55 7/16	36 7/16	23 3/4	9 1/2	9 1/2	9 1/2	2 1/2	5 1/2	36 7/16	
HB47	48 3/4	61 7/16	42 7/16	29 3/4	9 1/2	9 1/2	9 1/2	3	1	6 1/2	42 7/16

Convex	A	B	C	D	E	F	G	H	I	J	L
HB36	41	40 1/2	32 7/16	21 5/8	9 1/2	9 1/2	4	1 3/16	2 13/16	6 1/8	32 7/16
HB42	42 15/16	44 5/16	36 7/16	23 3/4	9 1/2	9 1/2	4	1 3/16	3 1/8	6 7/16	36 7/16
HB47	48	50 7/16	42 7/16	29 3/4	9 1/2	8 3/4	4	1 3/16	3 3/4	7 1/8	42 7/16

Installation of MQ Wall Mount Surrounds



Warning: Failure to position the parts in accordance with these diagrams or failure to use only parts specifically approved with this appliance may result in property damage or personal injury.

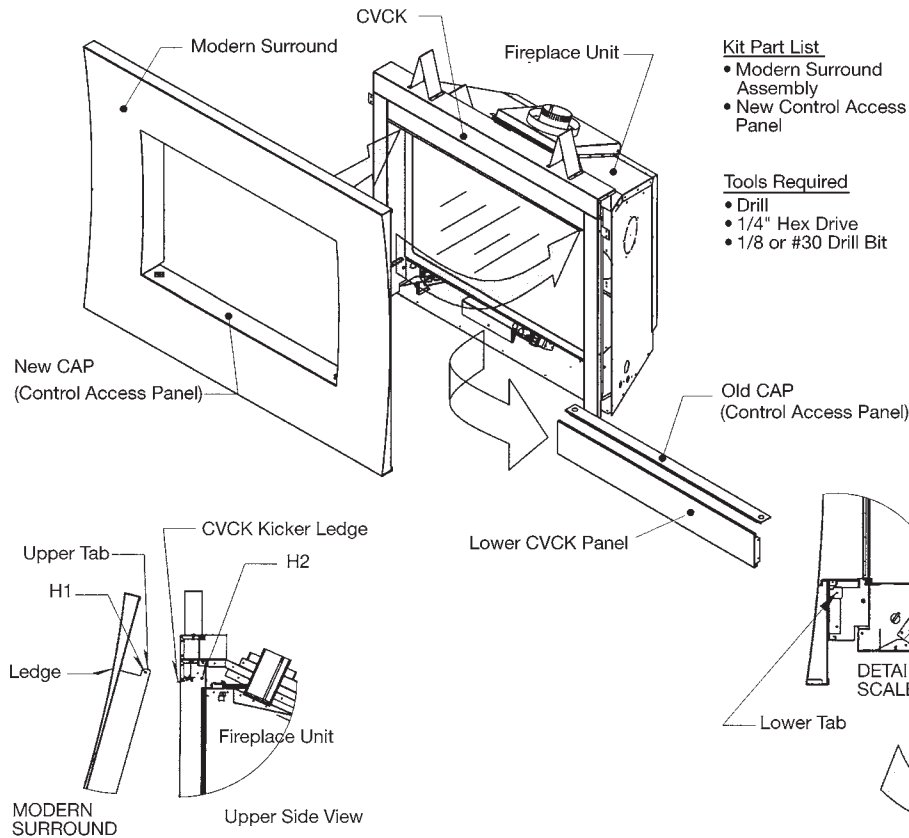

- Kit Part List**
- Modern Surround Assembly
 - New Control Access Panel
- Tools Required**
- Drill
 - 1/4" Hex Drive
 - 1/8 or #30 Drill Bit

Remove the old CAP (Control Access Panel), and the Lower CVCK panel by unscrewing the two support screws and drilling out the two rivets.

Remove the two upper CVCK mounting screws located at H2 as shown in the figure below. **IMPORTANT: KEEP ALL FOUR (4) SCREWS TO REMOUNT THE MODERN SURROUND ASSEMBLY.**

Slightly tilt the Modern Surround assembly so that the upper tab will clear the CVCK door opening.
 Slide the Modern Surround into the CVCK and align the holes H1 and H2. Please note that the ledge of the Modern Surround should rest on the CVCK Kicker Ledge.
 Using the previously removed screws, secure the upper tab of the Modern Surround in to the CVCK frame.

Swing lower portion of the Modern Surround into the CVCK and align the mounting holes on the Lower Tab with the holes on the CVCK Side Frame.
 Using the previously removed screws in Step 1, secure the Lower Tab to the CVCK side frame.
 Replace the old CAP with the new CAP that accompanied the Modern Surround kit.
 Check Installation to make sure the Surround and CVCK is secure.

Fan Installation for HBZDV 36/42/47

Fan Installation instructions for HBZDV36/42/47 with or without CVCK (Clean View Circulating Kit)

Note: INSTALL FAN KIT BEFORE INSTALLING OPTIONAL CVCK (Clean View Circulating Kit).

If CVCK has been installed into Framing additional access is provided by removing screws from bottom panel of CVCK. See INSTALLING CLEAN VIEW KIT (CVCK).

- Slide fan housing into unit and place over 2 Fan Retainer tabs. Tabs are pre punched and bent up. Rubber grommets at the base of the fan should fit snugly over the tabs. *Note: When installing fan, lay the fan on its back and slide into the Fireplace lengthwise. Once inside the fan can be stood upright and slid behind the valve for placement.
- Note: For Fan Disc installation HBZDV units have been installed with a sliding track system. Install the Thermdisc provided with the Fan Kit. Place thermdisc into sliding assembly, Fig 1, and attach 2 leads exiting right side of fan housing into thermdisc. Now slide disc assembly into thermdisc track, Fig 2. Place swivel handle of disc assembly on track to lock into position. To service disc simply pull swivel handle slide towards you while rotating handle to access disc.

Caution: Label all wires prior to disconnection when servicing controls. Wiring errors can cause improper and dangerous operation.

Verify proper operation after servicing.

Parts List:

- 1 ea. fan comes with 4 ft cord. Two 14' leads (female ends)
- 1 ea variable speed control (wall mount type)
- 1 ea thermdisc
- 1 thermdisc mount assembly

- Wire Junction Box to 120v and wall mounted variable speed control. Install a duplex outlet to junction box and plug fan into outlet.
- Turn the wall switch on (clockwise). Turn fireplace on. Once the sensor in unit reaches operating temperature (approximately 10 to 15 minutes) the fan will turn on. The fan can be switched off if desired by turning the wall switch fully counter clockwise.
- To set the minimum fan speed. Remove the variable switch from the wall mount. Turn the variable speed wall controller to its minimum setting (fully counter clockwise). Use the set screw on the side of variable speed controller to increase or decrease the minimum fan speed (lowering minimum fan speed will decrease sound level created by fan)
Reinstall switch into wall mount and cover with face plate.

Note: To service fan with CVCK kit installed see Removing Burner System in manual. If CVCK is finished with a MQSW Wall Surround, the MQSW may be removed by removing the 4 attachment screws and removing MQSW, allowing access into the bottom of fireplace to service blower.

Electrical Services

All optional fan kits are equipped with a 120V, 60Hz, .4amp blower.

Note: All electric connections are to be made in accordance with CSA Standard C22.1 - Canadian Electrical Code part I or with the National Electrical Code, ANSI/NFPA 70 (latest edition) and/or in accordance with local codes.



WARNING: Electrical Grounding Instructions. This appliance is equipped with a three-pronged (grounding) plug for your protection against shock hazard and should be plugged directly into a properly grounded three-prong receptacle. Do not cut or remove the grounding prong from this plug.

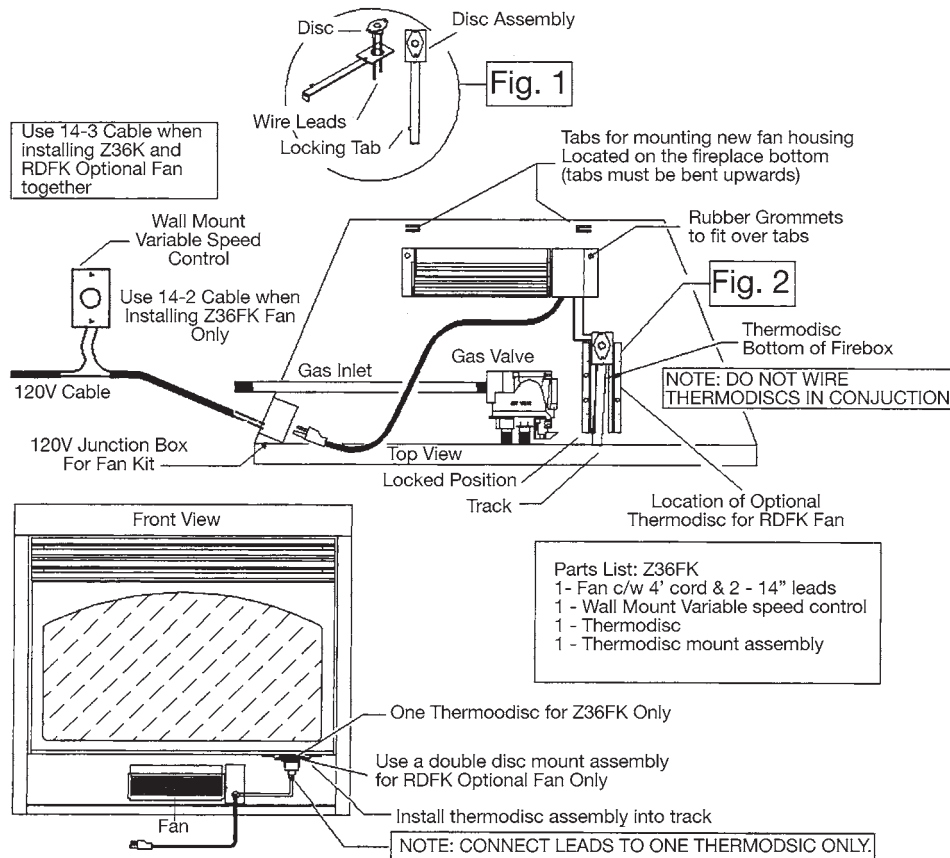

CAUTION – DO NOT ATTACH 120V FAN ASSEMBLY TO MILLIVOLT GAS VALVE SYSTEM

Split Receptacle- Fan Speed Control Outside of Fireplace

If you plan to locate the variable speed control switch for the fan outside of the fireplace and you require a constant source of AC power inside the unit for another accessory such as lights or an IPI valve system, follow one of the procedures below.

⚠ WARNING

A qualified electrician must connect electrical wiring to junction outlet for built-in installation.

Follow all codes.

⚠ WARNING

Electrical Grounding Instructions –
This appliance is equipped with a three – pronged (grounding) plug for your protection against shock hazard and should be plugged directly into a properly grounded three-prong receptacle.

⚠ WARNING

Label all wires prior to disconnection when servicing controls. Wiring errors can cause improper and dangerous operation. Verify proper operation and servicing.

⚠ Caution: Electrical installation to be done by a qualified installer. All wires must be connected and grounded in accordance with CSA Standard C22.1- Canadian Electrical Code part 1 or with the National Electrical Code, ANSI /NFPA 70 (latest edition) and /or in accordance with local codes.

Switch Controlled Split Receptacle With Switch At START Of Cable Run

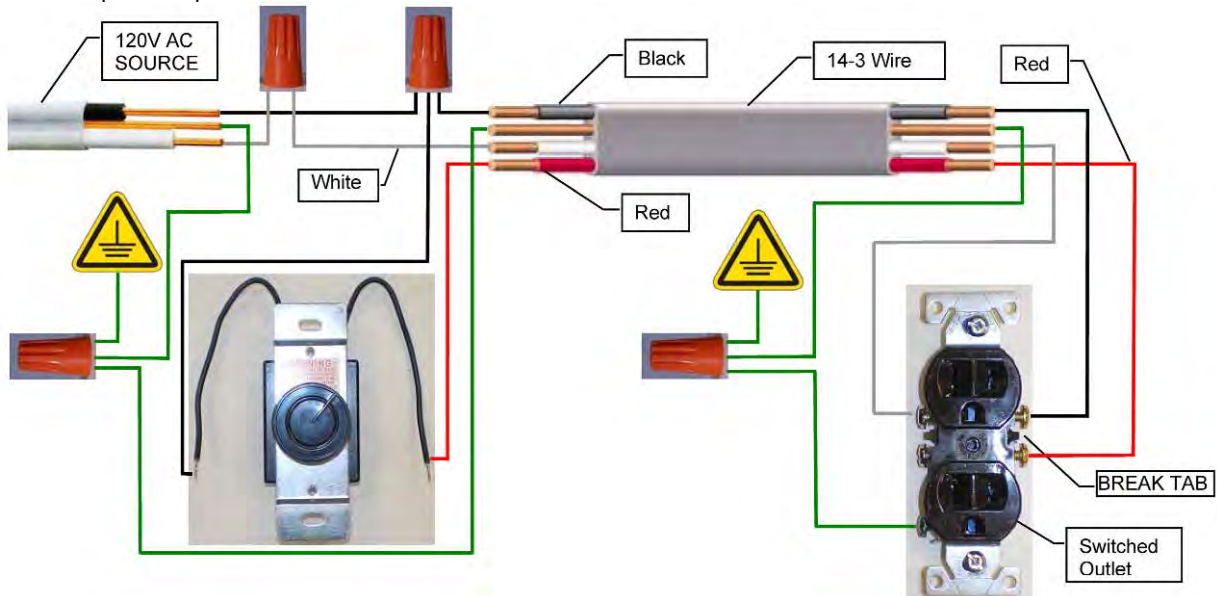

Switch Controlled Split Receptacle With Switch At END Of Cable Run

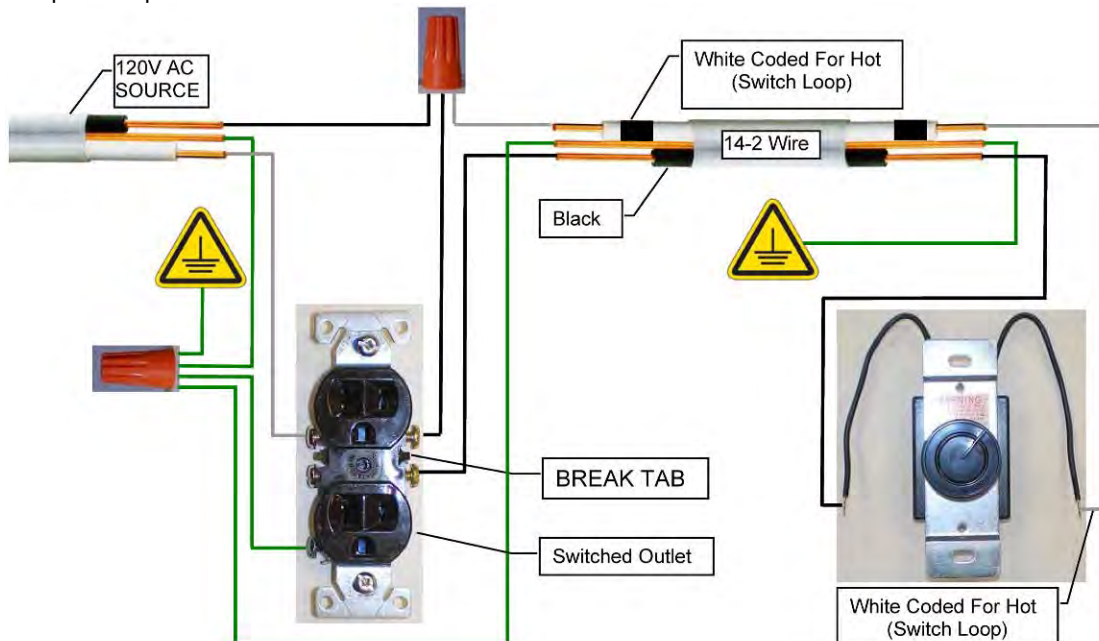

Installing MQRB4236 Liner Panels

There are several types of Liner Panels available for the MQRB4236:

- Flat Black Back Panel and False Bottom- (Supplied with Unit).
- Porcelain Back and Side Panels- **MQRB42PL**

Removal of False Bottom and Back Panel

1. Remove four [4] screws from False Bottom and lift out of the Firebox (**Ref.1**).
2. The Back Panel is held in place by the False Bottom and 2 Locking Tabs on the inside top of the Firebox (See **Ref.2** Below). Once the False Bottom is removed, slide the bottom of the Back Panel forward until it releases from these Tabs and then remove it from the firebox.

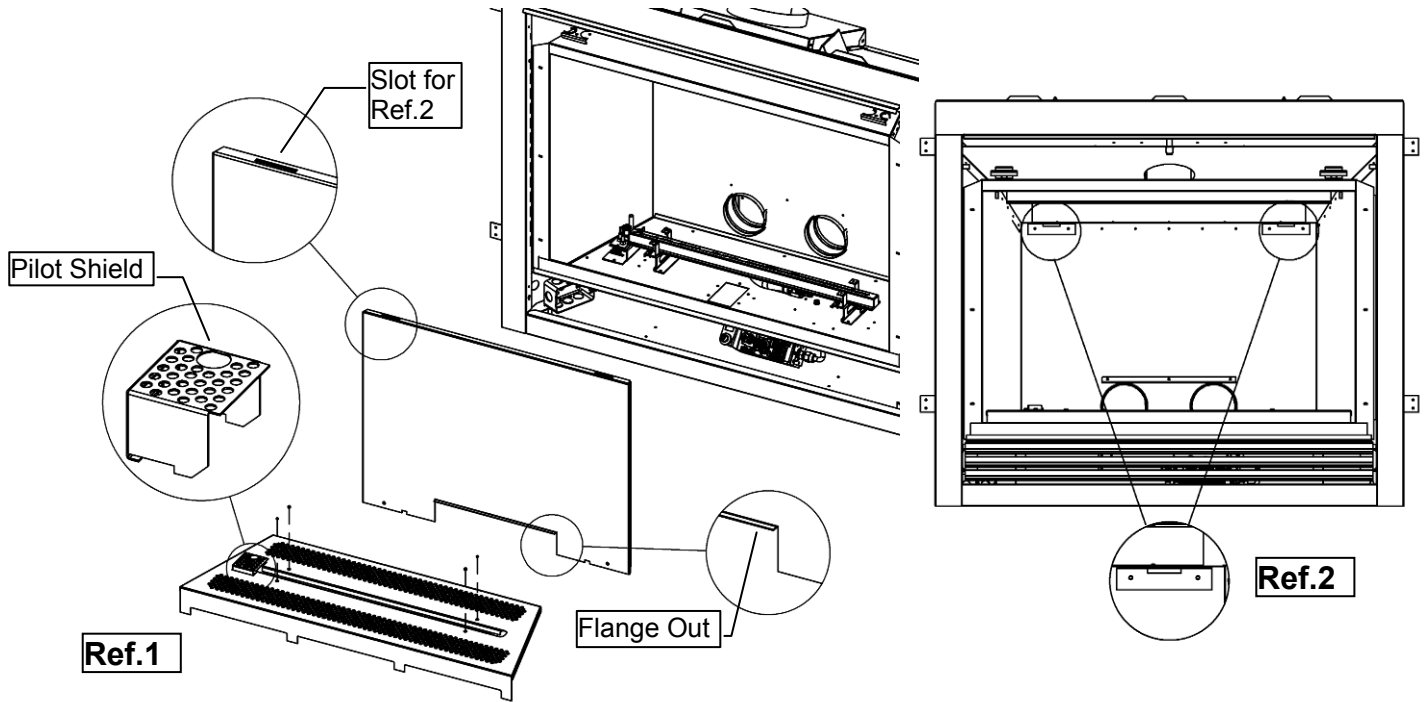

Installation of MQRB4236 Liner Panels

1. Remove 2 DT Screws from Firebox sides (Do not discard these screws). Place Side Panels into Firebox as shown in **Ref.3** below; tilt and slide into place. Replace and tighten DT Screw through hole in top of Side Panel and into side of Firebox.
2. Install Back Panel (**Be sure Flange is facing outward as per Ref.1**). Engage Slots into Locking Tabs in Firebox Top as shown (See **Ref.2** above). Slide Back Panel into place.
3. Place False Bottom over burner system (Pilot Ember Shield must be attached on Pilot side) and fasten with four [4] screws.

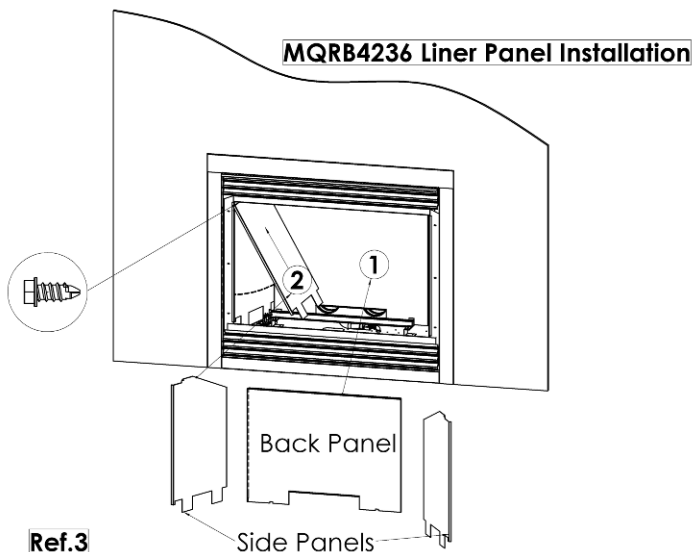

Parts List for MQRB42PL

- 1 Left Side Panel
- 1 Right Side Panel
- 1 Back Panel



Note: Warping and Discoloration of Porcelain or Painted Metal Liners Is Not Covered Under Warranty.

Both Porcelain and Painted Metal Liners may discolor and warp during normal operation of your appliance. This is normal, and not considered a defect.

Brick Installation - For Models MQHBZDV3636 / MQHBZDV4236 / HBZDV4736

INSTALLING BRICK PANELS FOR MODEL MQHBZDV3636 / MQHBZDV4236 / HBZDV4736

1. Remove door glass from the unit by unlatching the 2 latches on top of unit.
2. **HBZDV4736 ONLY**
Using a 1/4" nut driver remove two screws from Brick Panel Filler (#1) and discard brick panel filler. (Ref.1)
3. Remove back Log Holder (#2) by removing three screws from face of Log Holder. The Log Holder will have to be re-installed after the placement of Back Brick Panel. (Ref.1)
4. **HBZDV4736 ONLY**
Place optional front bridge ledge (#3) in the area front of false bottom.
5. Place rear Brick Panel (#4) up against the rear of Firebox by tilting top of panel towards you and sliding bottom of Panel over the back of burner system.
6. Loosen screws holding brick clip in position. Rotate clip up out of the way and slide side brick (#5) up against rear Brick. Side brick must be flush with side wall of Firebox. Rotate clip down over Brick Panel and tighten screw.

NOTE: Side Brick for MQHBZDV3636 & MQHBZDV4236

Top of side brick has to be tilted forward and hooked over bottom front lip of Firebox first then rotated backward into position.

7. Re-install Log Holder removed in Step 3.
8. Install log set as per instruction and re-install door.

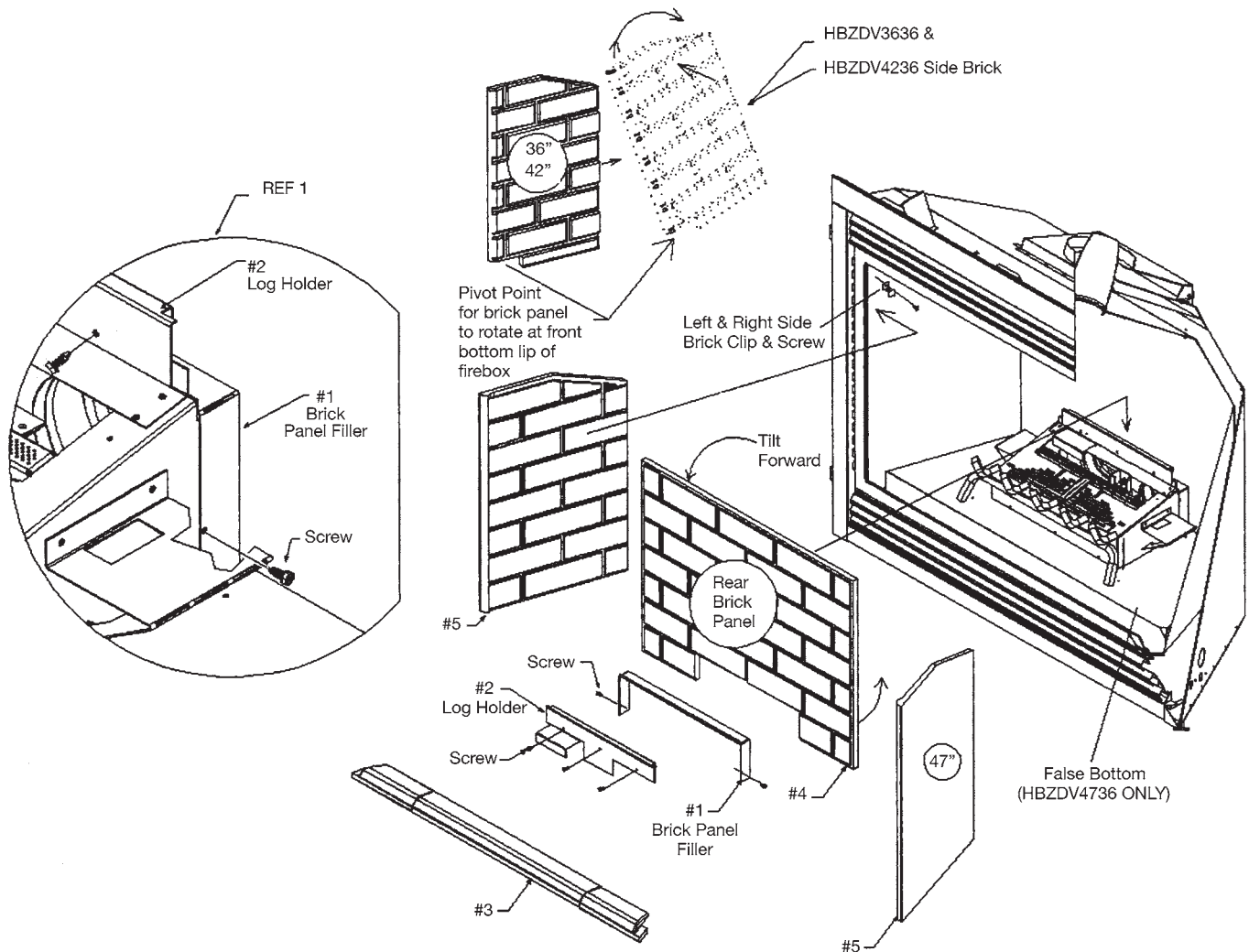

Installation of HB Porcelain Liners - HB36PL/HB42PL/HB47PL

1. Remove Door from the fireplace by unlatching the 2 latches on top of unit.
2. Remove back Log Holder by removing 3 screws from face of Log Holder. The Log Holder will have to be re-installed after the placement of the Back Panel. For HB4736, remove Brick Filler Panel (See Ref. 1).
3. Place Back Panel up against rear of firebox by tilting top of Back Panel towards you and sliding bottom of Back Panel over burner system. For HB47PL, use supplied screw to attach Back Panel to firebox (See Ref. 2).
4. Loosen screws holding Brick Clip in place. Rotate Brick Clip out of the way and slide Side Panel up against Back Panel. Side Panel tabs should engage top and bottom of Back Panel (See Ref. 3). Rotate Brick Clip down over Side Panel and tighten screw.
5. Re-install Log Holder (and Brick Filler Panel if applicable) removed in step 2. Install Log Set as per instruction and re-install Door.

Parts List:

- [1] Left Side Panel
- [1] Right Side Panel
- [1] Back Panel
- (HB47PL Only) [1] DT Screw

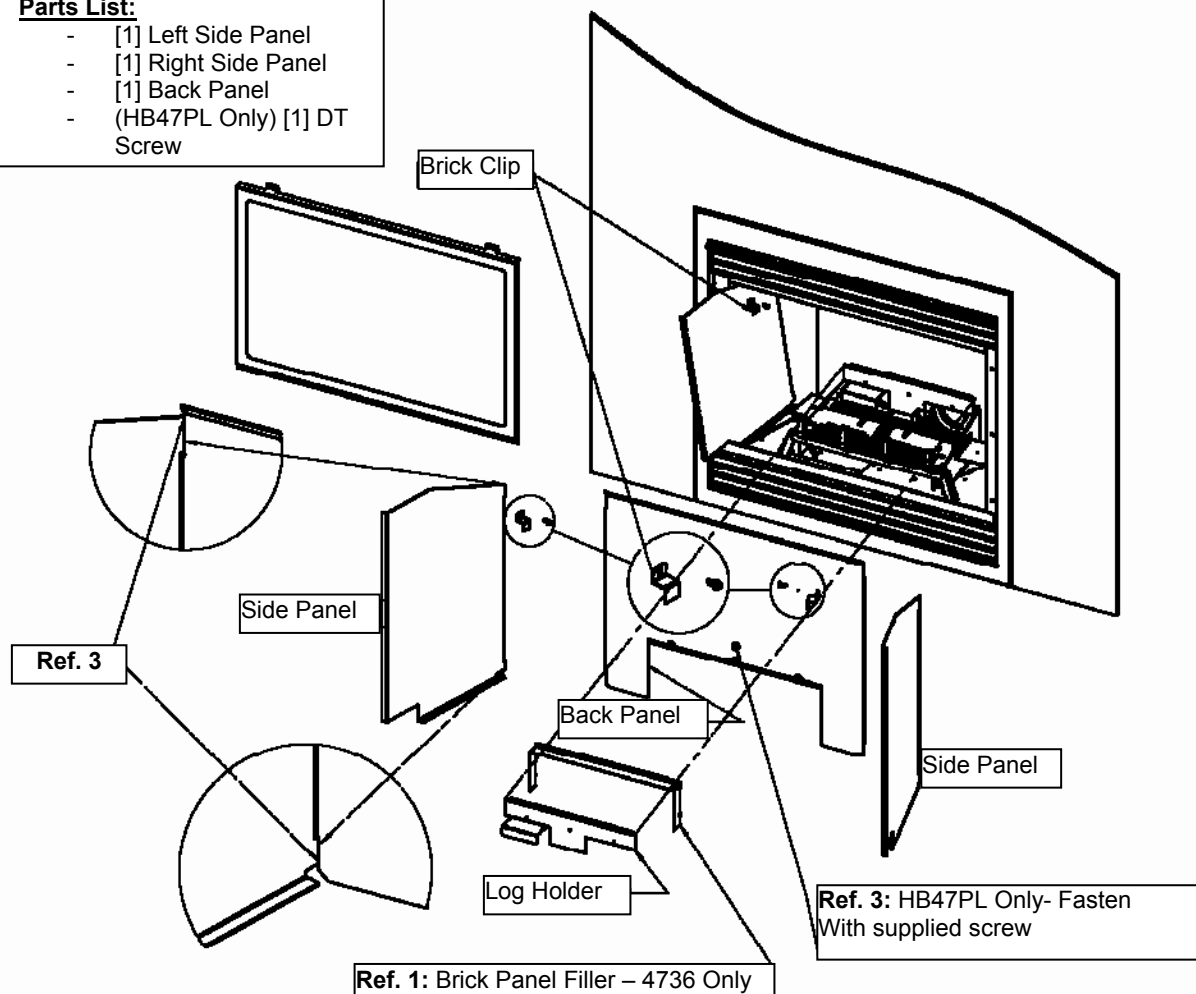

Note: Warping and Discoloration of Porcelain or Painted Metal Liners Is Not Covered Under Warranty.

Both Porcelain and Painted Metal Liners may discolor and warp during normal operation of your appliance. This is normal, and not considered a defect.

Gas Line Installation

This gas appliance should be installed by a qualified installer in accordance with local building codes and with current CAN/CGA - B149.1 or .2 installation codes for Gas Burning appliances and equipment in Canada and the National Fuel Gas Code ANSI Z223 in the U.S.A.

1. The gas pipeline can be brought in through either the right or the left side of the appliance.
A knockout is provided at either location to allow for the gas pipe installation and testing of any gas connection.
2. The gas control inlet is 3/8" NPT. Typical installation layout for rigid pipe is shown at right.
3. When using **copper** or **flex connector**, use only approved fittings. Always provide a union so that gas line can be easily disconnected for burner or fan servicing. See gas specification for pressure details and ratings.
4. When a vertical section of gas pipe is required for the installation, a condensation trap is needed. See CAN/CGA-B149.1 or .2 for code details.
5. For natural gas, a minimum of 3/8" iron pipe with gas minimum pressure of 4.5" w.c. must be used for supply from the gas meter. Consult with the local gas utility if any questions arise concerning pipe sizes.
6. A 1/8" NPT plugged tapping is accessible for test gauge connection both on the inlet and outlet of the gas valve.
7. Turn the gas supply ON and check for leaks. **DO NOT USE OPEN FLAME FOR THIS PURPOSE.** Use an approved leak testing solution.
8. The appliance and its individual shutoff valve must be disconnected from the gas supply piping system during any pressure testing of that system at test pressures in excess of 1/2 PSIG (3.5 KPa).
9. The appliance must be isolated from the gas supply piping system by closing its individual shutoff valve during any pressure testing of the gas supply piping system at test pressures equal to or less than 1/2 PSIG (3.5 KPa).

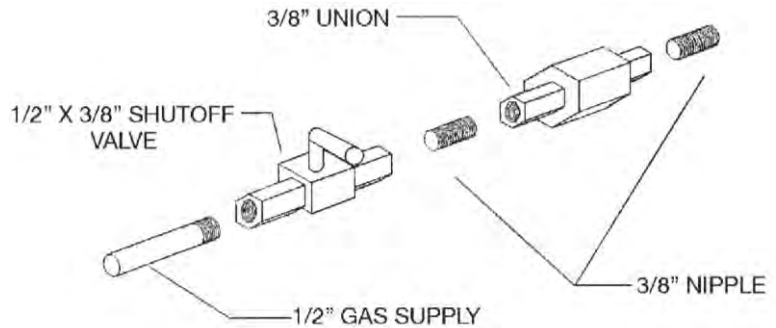

Note: The gas line connection may be made of 1/2" rigid pipe or an approved flex connector. Since some municipalities have additional local codes, it is always best to consult your local authorities and the current CAN/CGA - B149.1 or .2 installation code in Canada or the National Fuel Gas code ANSI Z223.1 in the U.S.A.

For the state of Massachusetts a **T-handle gas shut-off valve** must be used on a gas appliance. This T-handle gas shut-off valve must be listed and approved by the state of Massachusetts. This is in reference to the state of Massachusetts state code CMR238.

Important: Always check for gas leaks with a soap and water solution. Do not use open flame for leak testing.

Gas Specifications

Models	MQHBZDV						MQRB		
	HB4736N	HB4736LP	4236N	4236LP	3636N	3636LP	4236N	4236NT	4236LPT
Fuel	Natural	Propane	Natural	Propane	Natural	Propane	Natural	Natural	Propane
Gas Control	Millivolt Adjustable								
Maximum Input HI [Btu/hr]	40,000	36,000	30,500	29,200	30,500	29,200	30,500	24,000	24,000
Maximum Input LO [Btu/hr]	27,000	30,000	20,600	22,200	20,600	22,200	20,600	18,000	19,000
Maximum Output HI [Btu/hr]	27,200	24,100	23,180	22,100	23,200	21,900	23,180	-	-
Orifice Size (0-4500ft)	#31	#49	#36	#51	#36	#51	#36	#42	#53
Air Shutter Opening	5/16"	Fully Open	3/16"	5/16"	3/16"	5/16"	1/16"	1/32"	1/4"
Gas Inlet Size	S.I.T. 820 Nova, 3/8" NPT								
Gas Supply Pressure	Minimum	Normal	Maximum						
Natural Gas [in. w.c.]	5.5"	7"	9"						
Propane [in. w.c.]	11"	11"	12"						
Manifold Pressure	Nat. Gas		Propane						
High [in. w.c. / kPa]	3.5" / 0.87		10" / 2.61						
Low [in. w.c. / kPa]	1.6" / 0.40		6.3" / 1.57						

Millivolt System, Lighting, and Burner Control

FOR YOUR SAFETY READ BEFORE LIGHTING

WARNING: If you do not follow these instructions exactly, a fire or explosion may result causing property damage, personal injury or loss of life.

BEFORE LIGHTING

- | | |
|--|--|
| <p>A This appliance has a pilot which must be lighted by hand. When lighting the pilot, follow these instructions exactly.</p> <p>B Smell all around the appliance area for gas. Be sure to smell next to the floor because some gas is heavier than air and will settle on the floor.</p> | <ul style="list-style-type: none"> • Immediately call your gas supplier from a neighbour's phone. Follow the gas supplier's instructions. • If you cannot reach your gas supplier, call the fire department. <p>C Use only your hand to push or turn the gas control knob. Never use tools. If the knob will not push in or turn by hand, don't try to repair it. Call a qualified technician. Force or attempted repair may result in a fire or explosion.</p> <p>D Do not use the appliance if any part has been under water. Immediately call a qualified service technician to inspect the appliance and to replace any part of the control system which has been under water.</p> |
|--|--|

WHAT TO DO IF YOU SMELL GAS

- Do not try to light an appliance.
- Do not touch any electrical switch; do not use any phone in your building.

LIGHTING INSTRUCTIONS

1. Stop! Read the safety information above this label.
2. Set the thermostat to lowest setting.
3. Turn off all electrical power to the appliance.
4. Locate valve under the burner assembly.
5. If the control knob is not already in the off position, i.e. the word "OFF" in the 9 o'clock position, then push in the gas control knob slightly and turn ⤵ clockwise to "OFF". NOTE: Knob cannot be turned from "PILOT" to "OFF" unless knob is pushed in slightly. Do not use force.
6. Wait five [5] minutes to clear out any gas. If you then smell gas. STOP! Follow "B" in the safety information above on this label. If you don't smell gas then go to the next step.
7. Now push in the control knob slightly and turn ⤴ counter-clockwise to the "PILOT" position.
8. Push in the control knob all the way and hold it. With the other hand push in the red ignitor button until you hear a click. Now observe closely the pilot burner located on the rear center-left hand side of the main burner. If a flame has appeared then continue to depress the control knob for 20 seconds. If the flame did not appear then continue to depress the red ignitor button every 5 seconds until a flame is established. NOTE: If after 30 seconds a flame has not yet been established then turn the control knob back to the off position and repeat steps 5, 6 & 7.
9. Once the pilot has been established hold the control knob in the depressed position for approximately 25 seconds before releasing. If the flame goes out then repeat steps 7 and 8.
10. Now turn the control knob to the "ON" position. The burner will not light unless the wall switch thermostat or remote control is turned "ON" or in the case of the thermostat there is a call for heat.
11. Close the access door and turn all electrical power back to the appliance.

TO TURN OFF THE APPLIANCE

1. Set the thermostat to lowest setting.
2. Turn off all electric power to the appliance if service is to be performed.
3. Open the control access door.
4. Push in the gas control knob slightly and turn ⤵ clockwise to the "OFF" position. Do not force.
5. Replace control access panel.

NOTE: Only one on/off device (manual on/off, remote control, or hard wired thermostat) should be connected to the appliance at any one time, this is most important when installing a insert or stove as the on/off rocker switch is installed at the factory.

Recommended Maximum Lead Length (Double Wire)
When Using Wall Switch or Thermostat

Wire Size	Max. Length
14ga	100ft [30.4m]
16ga	64ft [19.5m]
18ga	40ft [12.1m]
20ga	25ft [7.6m]
22ga	15ft [4.5m]

CAUTION: DO NOT WIRE 120V POWER TO MILLIVOLT SWITCHES OR THERMOSTAT.

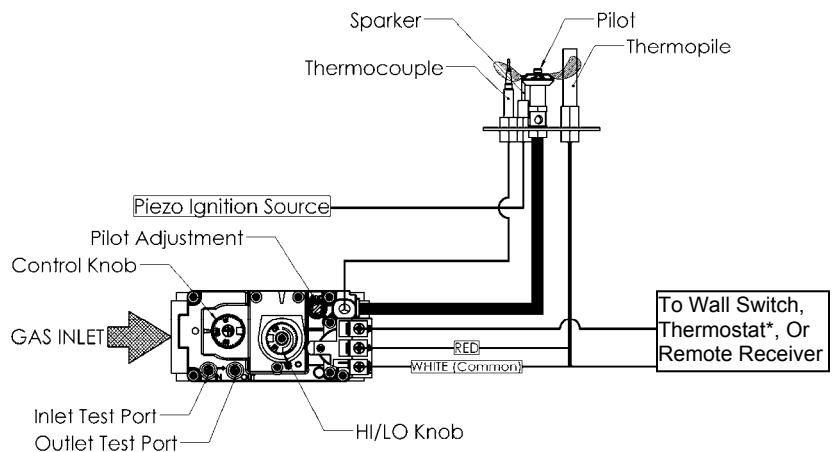

*In the U.S.A. Thermostats are not permitted for Vented Gas Fireplaces (ANSI Z21.50b-2009 -Decorative).

Trouble Shooting The Gas Control System



WARNING: BEFORE DOING ANY GAS CONTROL SERVICE WORK, REMOVE THE GLASS FRONT.

NOTE: Before troubleshooting the gas control system, be sure external gas shut off is in the “On” position.

Problem	Possible Causes	Corrective Action
Spark igniter will not light.	Defective or misaligned electrode at pilot.	Check for spark at electrode and pilot: if no spark and electrode wire is properly connected, replace igniter.
	Defective igniter (push-button)	Using a match, light pilot. If pilot lights, turn off pilot and push the red button again. If pilot will not light - check gap at electrode and pilot should be 1/8" to 1/4" to have a strong spark.
Pilot will not stay lit after carefully following lighting instructions.	Defective thermocouple (flame switch where applicable)	Check pilot flame. Must impinge on generator and thermo couple. Clean and/or adjust pilot for maximum flame impingement on generator and thermocouple. Replace thermocouple if pilot will not hold. (Hand tight 1/8 turn on replacement)
	Defective valve magnet.	Replace valve, if pilot won't hold after the thermocouple is replaced.
Pilot burning, no gas to burner, Valve knob “ON”, Wall Switch “ON”	Wall switch or wires defective	Check wall switch and wires for proper connections. Jumper wire across terminals at wall switch. If burner comes on, replace defective wall switch. If okay, jumper wires, across wall switch wires at valve. If burner comes on, wires are faulty or connections are bad.
	Generator may not be generating sufficient voltage.	Check generator with millivolt meter. Take reading at generator terminals of gas valve. Should read 325 millivolts minimum while holding valve knob depressed in pilot position and wall switch “off”. Replace faulty generator if reading is below specified minimum.
	Plugged burner orifice.	Check burner orifice for stoppage and remove.
	Defective automatic valve operator.	Remove wall switch wires from gas valve. Install jumper wires from top bottom terminals of gas valve. Turn valve on “ON”. If main burner does not light, replace valve.
Frequent Pilot outage problem.	Pilot flame may be too low or blowing (high) causing the pilot safety to drop out.	Clean and/or adjust pilot flame for maximum flame impingement on generator and thermocouple.
Flame lifts off burner and goes out in less than 30 seconds	Inner 4" liner has come off flue or termination, flame is starving for oxygen	Attach 4" liner to flue or termination using screws, silicone and clamps as stated in manual.
Flame lifts off burner on one side while the rest of the flame remains lit.	Improper installation of firebrick. Firebrick is likely leaning.	Be sure to position firebrick against firebox walls and be sure to use brick clips attached to the inner side of firebox.

Burner System Removal for MQHB36/42/47



Warning: Failure to position the parts in accordance with these diagrams or failure to use only parts specifically approved with this appliance may result in property damage or personal injury.

Removing Burner System / Access Cover for MQHBZDV36/42/47

If fireplace has been installed with optional CVCK (Clean View Circulating Kit) to service fan system or burner system controls, the access cover and burner system pan will have to be removed.

CAUTION: BEFORE STARTING REMOVAL OF PARTS TURN OFF GAS SUPPLY. DISCONNECT 110 VOLTS TO FAN SYSTEM AND DISCONNECT 110 VOLTS TO ELECTRONIC IGNITION BURNER SYSTEM IF APPLICABLE

Access Cover Removal

1. Remove door, logs, brick panels, false bottom, burner grate and burner from firebox.
2. Burner grate is fastened by 2 screws there is one right and left of grate assembly, remove screws and take out grate.
3. **MQHBZDV47 ONLY.** Lift false bottom up from screw alignment points and remove.
MQHBZDV47 skip steps 4 to 8.
4. Remove ember plates right and left of burner, ember plates are held in place by 2 screws each.
5. Loosen screws from burner retainer tabs and slide burner to the left to remove from orifice.
6. Remove rear log holder by removing the 2 screws on each side of log holder.
7. Remove left side log support by removing the 2 screws from side of support.
8. Remove left ember plate support by removing 2 screws at base of support.
9. Remove 10 screws holding access cover in place. Push down on one corner of access cover to break seal of cover, once loose cover can be slid under firebox bottom to expose gas connection.

Removing Burner System

1. Disconnect gas line connection at burner system through access cover opening.

• **CAUTION: ALL WORK SHOULD BE PERFORMED BY A QUALIFIED AND CERTIFIED TECHNICIAN.**

2. Remove extension knobs and wiring from face of gas valve.
3. Remove false bottom. Undo screws holding back log holder and remove.

Remove screws from perimeter of burner system pan, lift pan at one back corner and rotate pan up from back of firebox. Make sure when tilting up and removing burner system that all fan and valve control wiring is disconnected at this time.

To re-install access cover / burner system remove old Mil Pac sealant and apply new sealant. After new sealant is applied reverse removal procedure to re-install parts.

CAUTION: High temperature sealant has been applied to access cover and burner system pan. New sealant will have to be applied when re-installing access cover and burner system to maintain the integrity of sealed combustion chamber. Mil Pac part #840099 or Kingsman part #1000-150MP sealant can be purchased from your Kingsman retailer or distributor.

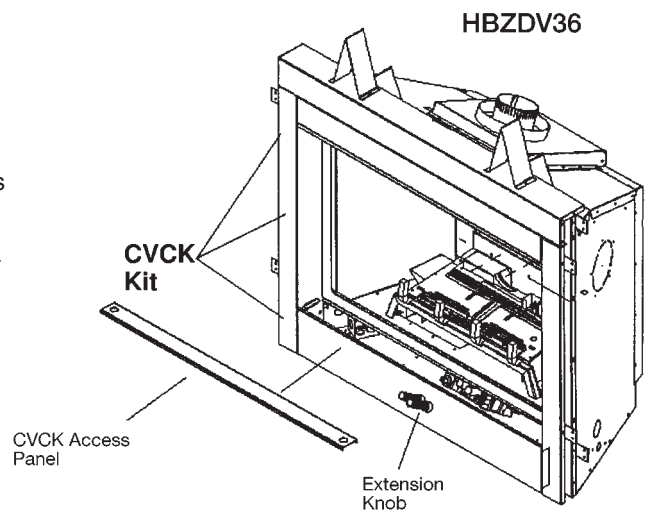

MQHBDV3636 & MQHBZDV4236 Burner System

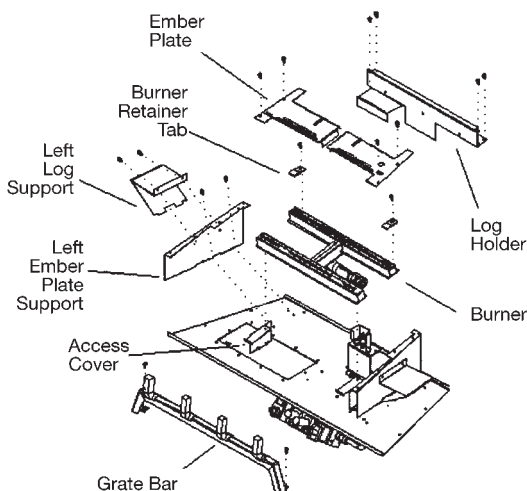

MQHBZDV4736 Burner System

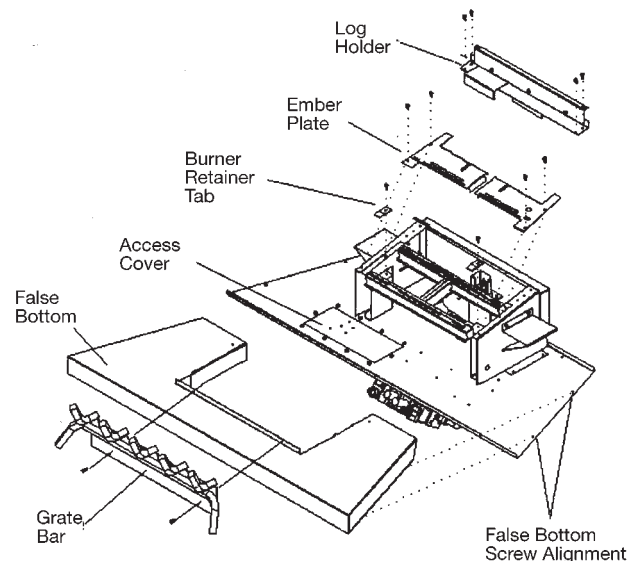

Burner System Maintenance

It is recommended to annually inspect and clean the Burner System to prevent malfunction and / or sooting. This operation should be performed by your dealer or a qualified technician.

-CAUTION-

Before servicing the burner system ensure that the gas supply is turned OFF and disconnect all electrical connections to the appliance. Allow the appliance to cool to room temperature. Note that the pilot assembly may be hot in an intermittent or standing-pilot system—even if the main burner was never on. Exercise caution when working within the area.

-ALL WORK SHOULD BE PERFORMED BY A QUALIFIED AND CERTIFIED TECHNICIAN-

Monthly Flame Inspection

It is recommended to turn on the unit at least once a month and inspect the flame pattern to ensure there are no problems with the burner tube. The pilot flame should also be inspected monthly to ensure proper operation.

MQHBZDV3636, MQHBZDV4236, HBZDV4736



Flame should appear similar to the above picture – Solace Series

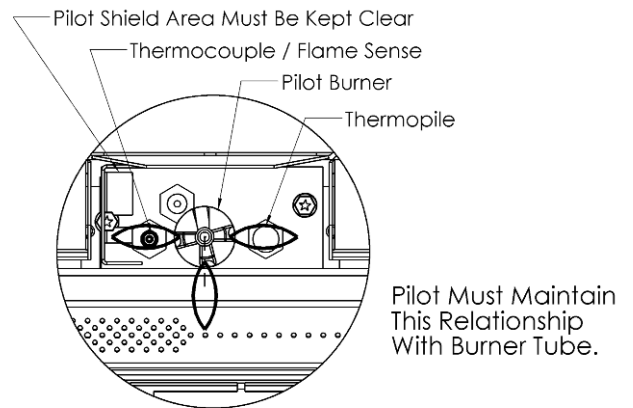

MQRB4236



Flame should appear similar to the above picture

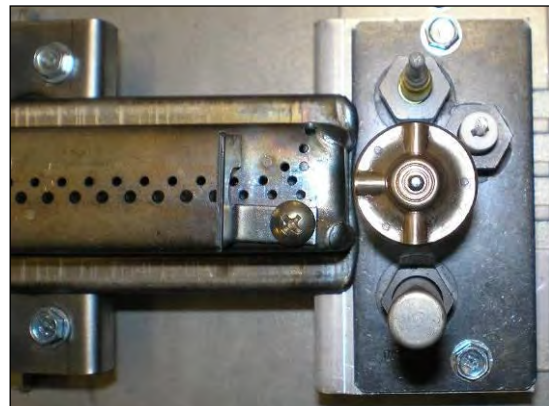

Pilot must maintain this relationship with burner.

Conversion Kit Instructions – PART A

Kit Number	Description	Pilot Orifice	Burner Orifice Brass (1000-255)	Brass Nipple	Air Shutter	Hi/Lo Regulator
3632HB -CKLP For MQHBZDV3636LP	LP Conversion -Millivolt-	1001-P167SI #30 (977.167)	#51	1000-253closed	5/16"	1001-P202SI (0.907.202)
3632HB -CKLPI For MQHBZDV3636LPE	LP Conversion -IPI -	1001-P168SI #35 (977.168)	#51	1000-253closed	5/16"	1002-P014SI (0.907.014)
3632HB -CKNG For MQHBZDV3636N	NG Conversion -Millivolt-	1001-P165SI #51 (977.165)	#36	1000-253closed	3/16"	1001-P201SI (0.907.201)
3632HB -CKNGI For MQHBZDV3636NE	NG Conversion - IPI -	1001-P166SI #62 (977.166)	#36	1000-253closed	3/16"	1002-P016SI (0.907.016)
4232HB-CKLP For MQHBZDV4236LP	LP Conversion -Millivolt-	1001-P167SI #30 (977.167)	#51	1000-253closed	5/16"	1001-P202SI (0.907.202)
4232HB -CKLPI For MQHBZDV4236LPE	LP Conversion -IPI -	1001-P168SI #35 (977.168)	#51	1000-253closed	5/16"	1002-P014SI (0.907.014)
4232HB -CKNG For MQHBZDV4236N	NG Conversion -Millivolt-	1001-P165SI #51 (977.165)	#36	1000-253closed	3/16"	1001-P201SI (0.907.201)
4232HB -CKNGI For MQHBZDV4236NE	NG Conversion - IPI -	1001-P166SI #62 (977.166)	#36	1000-253closed	3/16"	1002-P016SI (0.907.016)
4236RB-CKNG For MQRB4236N	NG Conversion -Millivolt-	1001-P165SI #51 (977.165)	#36	1000-P201VE Hex	3/16"	1001-P201SI (0.907.201)
4236RB-CKNGI For MQRB4236NE	NG Conversion - IPI -	1001-P166SI #62 (977.166)	#36	1000-P201VE Hex	3/16"	1002-P016SI (0.907.016)
4236RBT-CKLP* For MQRB4236LPT	LP Conversion -Millivolt-	1001-P167SI #30 (977.167)	#53	1000-P201VE Hex	1/4"	1001-P201SI (0.907.201)
4236RBT -CKLPI* For MQRB4236LPTE	LP Conversion -IPI -	1001-P168SI #35 (977.168)	#53	1000-P201VE Hex	1/4"	1002-P016SI (0.907.016)

***NOTE:** The **MQRB4236N** CANNOT BE CONVERTED TO LP.

**If the MQRB4236NT you wish to convert to LP has a serial number less than #4708
You MUST order the 4236RB-SRKP upgrade kit. (See Gas Conversion –Part A drawings which follow)**

4236RBT-CKNG For MQRB4236NT	NG Conversion -Millivolt-	1001-P165SI #51 (977.165)	#42	1000-P201VE Hex	1/32"	1001-P201SI (0.907.201)
4236RBT-CKNGI For MQRB4236NTE	NG Conversion - IPI -	1001-P166SI #62 (977.166)	#42	1000-P201VE Hex	1/32"	1002-P016SI (0.907.016)
4740HB-CKLP For HBZDV4736LP	LP Conversion -Millivolt-	1001-P167SI #30 (977.167)	#49	1000-253closed	Fully Open	1001-P201SI (0.907.201)
4740HB-CKLPI For HBZDV4736LPE	LP Conversion -IPI -	1001-P168SI #35 (977.168)	#49	1000-253closed	Fully Open	1002-P016SI (0.907.016)
4740HB-CKNG For HBZDV4736N	NG Conversion -Millivolt-	1001-P165SI #51 (977.165)	#31	1000-253closed	5/16"	1001-P201SI (0.907.201)
4740HB-CKNGI For HBZDV4736NE	NG Conversion - IPI -	1001-P166SI #62 (977.166)	#31	1000-253closed	5/16"	1002-P016SI (0.907.016)

Refer to "Gas Specifications Chart" for inlet pressures and input ratings. Clock meter to verify input rate. Place conversion label as close to converted gas control as possible. Refer to lighting instructions to verify the normal operating sequence of the ignition system. **IMPORTANT:** Always check for gas leaks with a soap and water solution.
DO NOT USE OPEN FLAME FOR LEAK TESTING.

MQHB3636/4236 / HBZDV4736 Gas Conversion –Part A



WARNING: This conversion kit shall be installed by a qualified service agency in accordance with the manufacturer's instructions and all applicable codes and requirements of the authority having jurisdiction. If the information in these instructions is not followed exactly a fire, explosion or production of carbon monoxide may result causing property damage, personal injury or loss of life. The qualified service agency is responsible for the proper installation of this kit. The installation is not proper and complete until the operation of the converted appliance is checked as specified in the manufacturer's instructions supplied with kit.



Caution:

The gas supply shall be shut off prior to disconnecting the electrical power, before proceeding with the conversion.

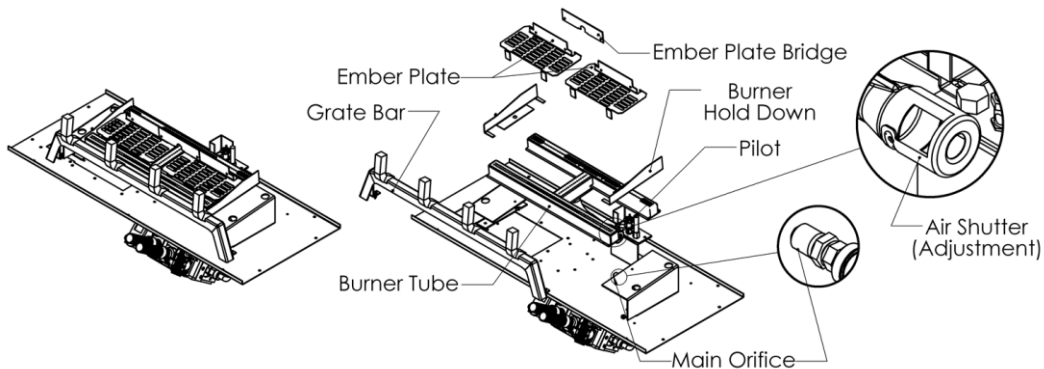

1. Remove ember plates right and left of burner, ember plates are held in place by 2 screws each.
2. Loosen screws from burner retainer tabs and slide burner to the left to remove from orifice.
3. Remove main orifice using a 1/2" wrench and replace with new conversion orifice.
4. Install new pilot orifice and Hi/Lo valve regulator by following instructions supplied with conversion kit (also See Parts B & C).
5. Adjust the primary air setting to the correct setting as specified in the manual or label plate. To adjust air setting, loosen screw on the side of air mixing tube and rotate to the correct opening using a drill bit or tape measure. Retighten screw.
6. Reinstall ember plates and burner by reversing steps 1 & 2.

Gas Conversion –Part A – MQRB4236

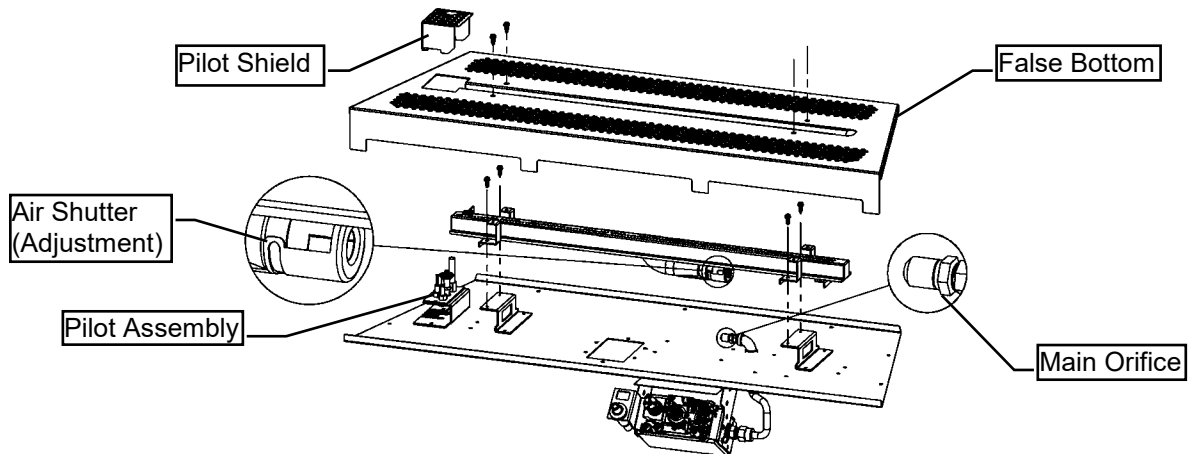

1. Remove four [4] screws holding down the false bottom. Remove the four [4] screws holding down the burner tube assembly.
2. Slide the burner tube towards the left to remove from orifice.
3. Remove main orifice using a 1/2" wrench and replace with new conversion orifice.
4. Install new pilot orifice and Hi/Lo valve regulator by following instructions supplied with conversion kit (also See Parts B & C).
5. Adjust the primary air setting to the correct setting as specified in the manual or label plate. To adjust air setting, loosen screw on the side of air mixing tube and rotate to the correct opening using a drill bit or tape measure. Retighten screw.
6. Reinstall false bottom and burner by reversing steps 1 & 2. Pilot Shield must be in placed over pilot assembly.

Gas Conversion for Top Convertible Pilot (Series 019065X) – PART B

Instructions for converting SIT 190 series pilot burner injection from NG to LPG and from NG to LPG only. This information should be considered as supplemental to the Appliance Manufacturer's Instructions.

WARNING: The installation of this conversion kit must only be undertaken by a qualified and certified gas appliance installer.

1. Shut off the gas supply to the appliance.
2. Allow the pilot burner to cool to room temperature.
WARNING: Touching a hot pilot burner can result in injury.
3. The pilot hood is held in place by spring pressure. Remove the hood by pulling it directly up from the pilot bracket (a).
4. Insert a 5/32" or 4mm Allen wrench into the hexagonal key-way of the injector (b), and rotate it counter-clockwise until it is free of the injector journal (c).
5. Verify that the new injector is proper for the application. The injector size is stamped on the side of the injector near the top. LPG injectors have a groove machined around their circumference near the top, while NG injectors do not have a groove (e). Refer to the Appliance Manufacturers instruction sheet for the proper injector size.
6. Insert the Allen wrench into the end of the injector. Then, insert into injector journal, and rotate the injector clockwise until a torque of 9 in-lbs is achieved.
7. Replace the pilot hood by aligning the tab on the base of the hood with the slot in the side of the pilot journal, and push the hood down, directly onto the pilot bracket (d). The hood must sit squarely on the bracket for proper operation. Check to insure that the hood is properly seated onto the pilot bracket.



(a)



(b)

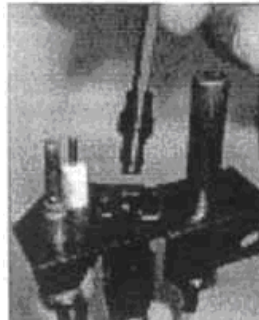

(c)

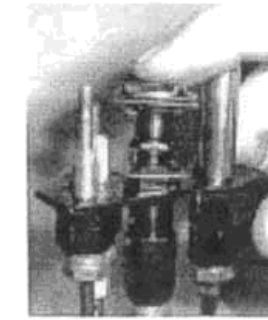

(d)

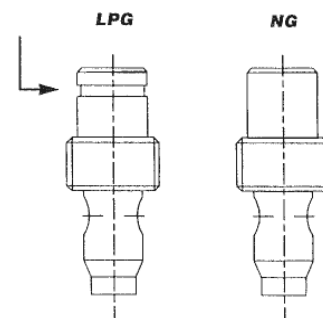

(e)



WARNING: This conversion kit must only be applied as part of a conversion kit supplied by the appliance Manufacturer for the specific appliance, and type of gas being converted.

INSTALLER NOTICE: These instructions must be left with appliance.

installation instructions

7 252 136

820 NOVA mV

Modulating Conversion Kit



-WARNING!

The installation of this conversion kit must only be undertaken by a qualified and certified gas appliance installer.

MODULATING PRESSURE REGULATOR CONVERSION KIT INSTALLATION OR REPLACEMENT INSTRUCTIONS.

- 1 Turn control knob to the OFF position, and shut off the gas supply to the valve.
- 2 Using a Torx T20, or slotted screwdriver, remove and discard the three pressure regulator mounting screws (A), pressure regulator tower (B), and the spring and diaphragm assembly (C) (if applicable)
- 3 Insure that the rubber gasket (D) is properly positioned and install the new modulating pressure regulator assembly to the valve using the new screws (E) supplied with the kit. Tighten screws securely. (Reference torque = 25 In.Lb.)
- 4 Install the enclosed identification label (F) to the valve body where it can be easily seen.
- 5 Apply gas to system and re-light appliance according to manufacturers instructions.
- 6 With the main burner "ON", test the new pressure regulator assembly for leaks using a soap solution.
- 7 Relight the main burner in both the HI and LO positions, and verify proper burner ignition and operation.

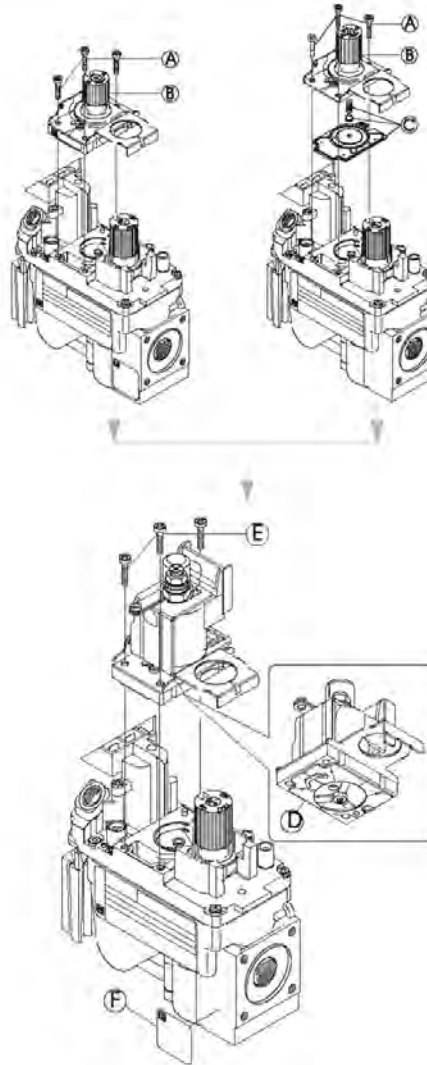

-WARNING!

This modulating conversion kit must ONLY be applied as part of a conversion kit supplied by the APPLIANCE MANUFACTURER for the specific appliance, and type of gas, being converted.

INSTALLER NOTICE. These instructions must be left with appliance.



SIT Group

Door and Glass Information

Glass Cleaning

It will be necessary to clean the glass periodically. During start-up, condensation, which is normal, forms on the inside of the glass and causes dust, lint etc. to cling to the glass surface. Also, initial paint curing can deposit a slight film on the glass. It is therefore recommended that initially the glass be cleaned two or three times with non-abrasive common household glass cleansers and warm water. After that, the glass should be cleaned two or three times a season depending on the circumstances.



Warning and Cautions.

- Do not clean when the glass is hot.
- Do not use abrasive cleaners.
- Using a substitute glass will void all product warranties.
- Do not strike or abuse glass. Care must be taken to avoid breakage of the glass.
- Do not operate this fireplace without the glass front or with a broken glass.

Glass Replacement

REPLACEMENT GLASS FOR BOTH DIRECT VENT UNITS

Model Series HBZDV4736 use Low E Tempered Glass. Must be 5mm thick.

Only Robax ceramic or coated Neoceram glass may be used for replacement for model MQHBZDV3636, MQHBZDV4236 and MQRB4236. Must be minimum 5mm thick.

To replace glass, clean all materials from door frame. Scrape off old silicone down to metal. Using a high heat silicone temperature-resistant to 500°F (260°C) apply a continuous bead of approximately 1/32" to all four sides of frame and insert glass with new gasket. Frame should be on flat surface, with a small amount of weight pressing glass into silicone. Let dry approximately 15 to 20 minutes. The door can be re-installed by reversing Steps 1 & 2. Use caution when removing broken glass, wear gloves.

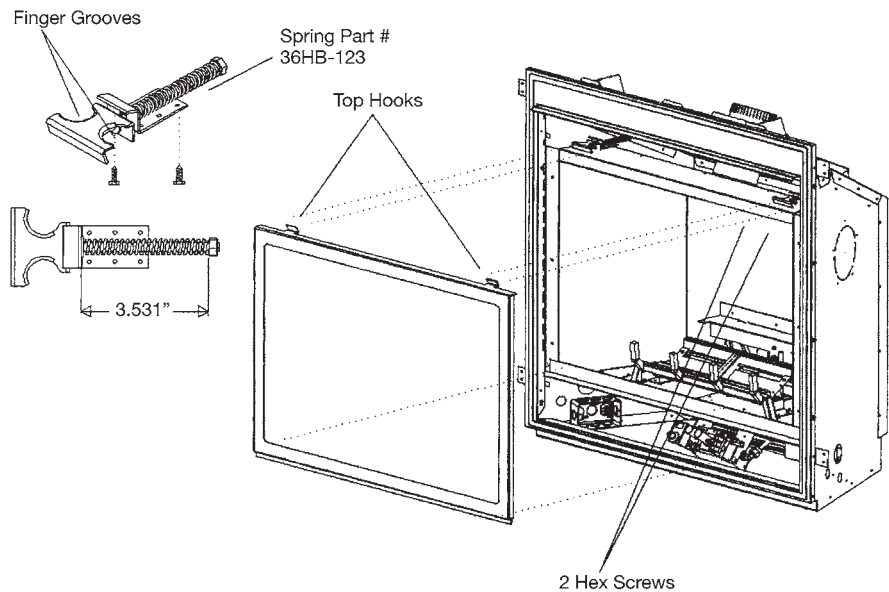

Removal of the Glass Door

1. Remove the door by unlatching the 2 top latches. Simply place 2 fingers in the grooves, pull towards you and lift upwards slightly.
2. Once the top of the door is unlatched, simply pull outwards and lift upwards to unlatch the bottom.
3. When re-installing the door place the bottom of the door in first and secure with Top Latch assembly to the door.

Spring Replacement:

- *Over time, spring may need to be replaced if tension is lost.
1. To remove the top latch, remove the 2 hex screws that secure it in place. They are located in the firebox.
 2. Once all the screws are removed the latches will slide out of place.
 3. There is 1 lock nut per latch. When replacing a spring, tighten the lock nut until 2 threads are beyond the locknut. This is critical for proper tension.

Appliance/Log Reference Chart/Log Placement

The following is a list of models and appropriate log sets that can be used with each model. It is important that the appropriate log set is used with the correct model in order for the appliance to work properly.

Appliance	LOGF36	MQRSP1 MQROCK1	MQRSP2 MQROCK1
MQHBZDV3636N or LP	✓		✓
MQHBZDV4236N or LP	✓		✓
HBZDV4736N or LP	✓	✓	

LOG PLACEMENT - LOGF36



WARNING: Failure to position the parts in accordance with these diagrams or failure to use only parts specifically approved with this appliance may result in property damage or personal injury.



PARTS LIST

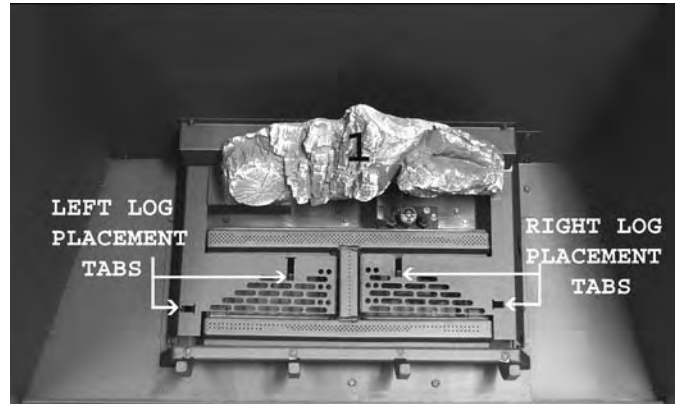

STEP 1: Place log #1 onto rear log holder and center.



STEP 2: Place log #2 onto left side of log. Place log #3 onto right side of log #1.



STEP 3: Locate 2 holes on the bottom of logs #4 and #5. Position them onto left and right log placement tabs.



STEP 4: Locate the hole on the bottom of log #6. Place onto the mounting tab on log #2. Locate the 2 holes on the bottom of log #7. Place onto mounting tabs on log #5.



STEP 5: Place glowing embers on the front of the burner tube and ember plates. Place lava rock and vermiculite on the burner pan as shown. **DO NOT PLACE LAVA ROCK AND VERMICULITE ON BURNER TUBE.**

Pilot Shield RSP1 / RSP2

Qty: 1 Shield Per Kit

1

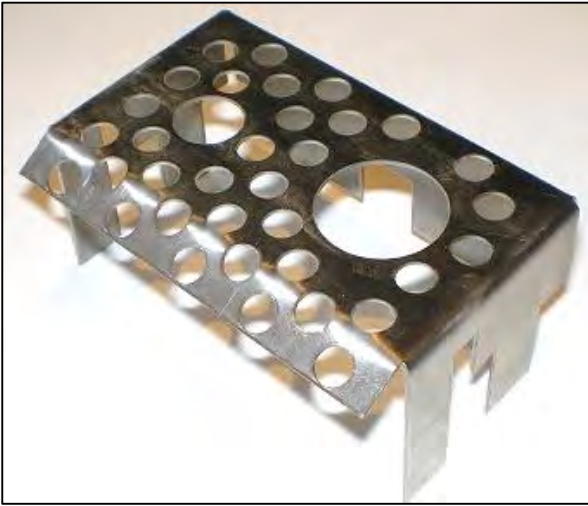

2

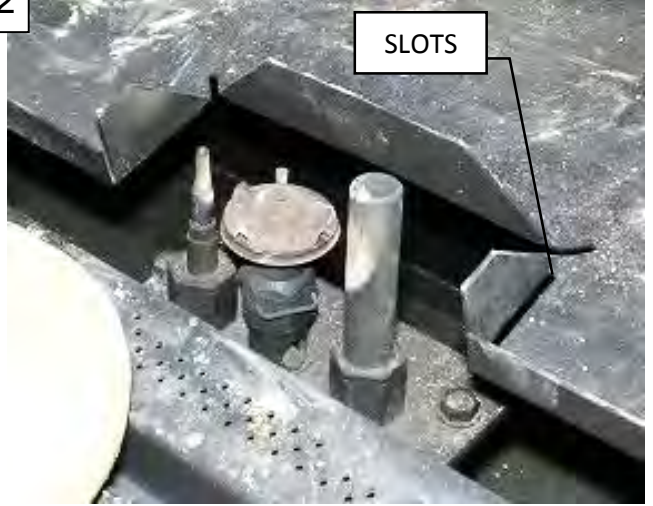

3



4

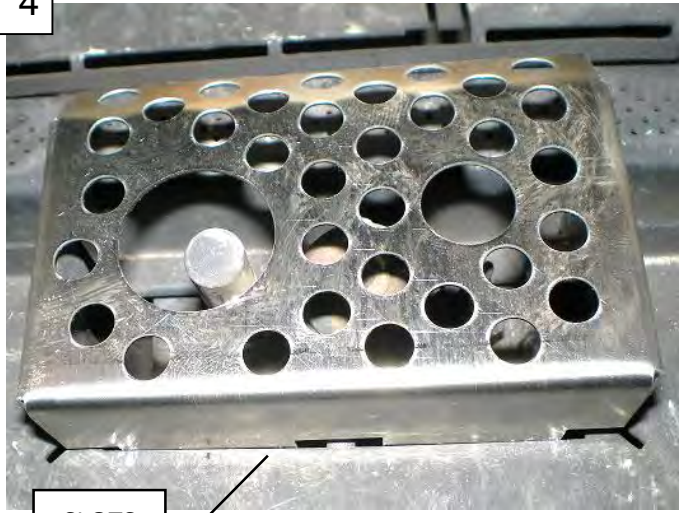

5

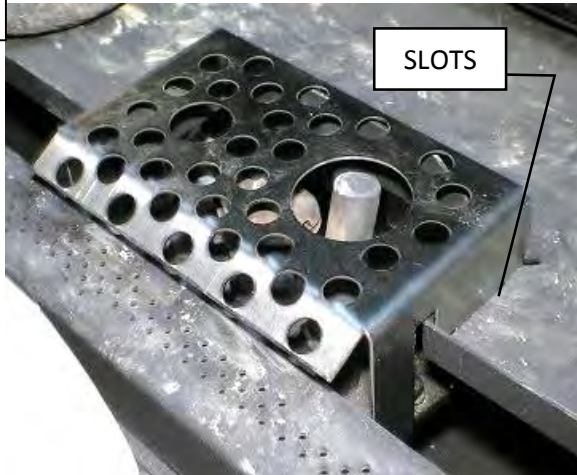

6

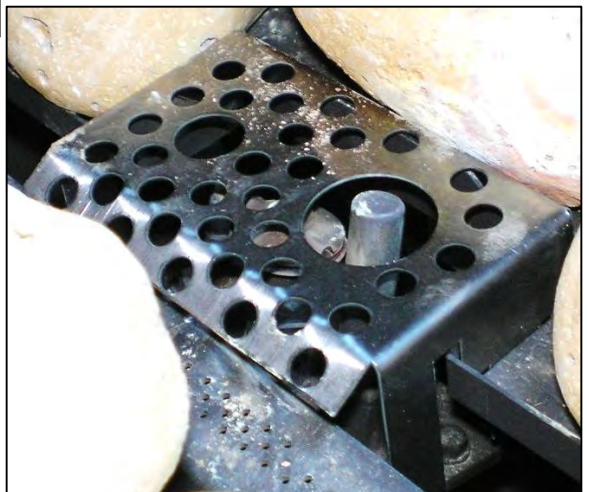

MOROCK1/MORSP2 Setup for Models MOHBZDV3636/MOHBZDV4236

! WARNING: Failure to position the parts in accordance with these diagrams or failure to use only parts specifically approved with this appliance may result in property damage or personal injury.

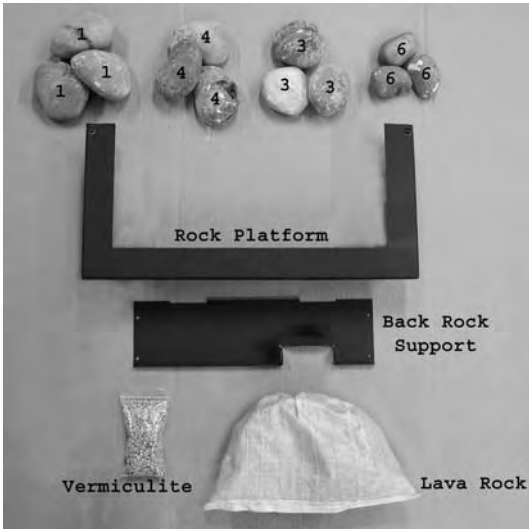

PARTS LIST

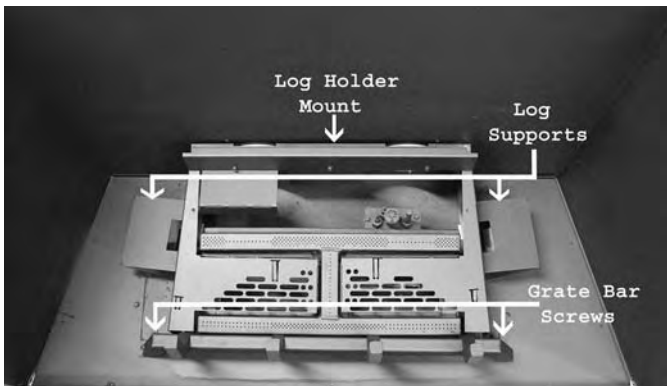

STEP 1: Remove the log holder mount, log supports, and the grate bar.

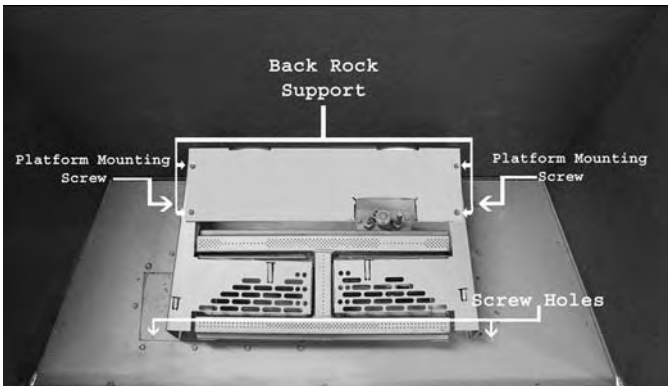

STEP 2: Attach the back rock support with the 4 screws as shown. Replace/reinstall the 2 screws from the grate bar.



STEP 3: Using the platform mount access holes, attach the rock platform as shown.



STEP 4: Fill around the rock platform with lava rock. Do not place any lava rock on the burner. Sprinkle vermiculite over top of the lava rock.

MOROCK1/MORSP2 Setup for Models MOHBZDV3636/MOHBZDV4236

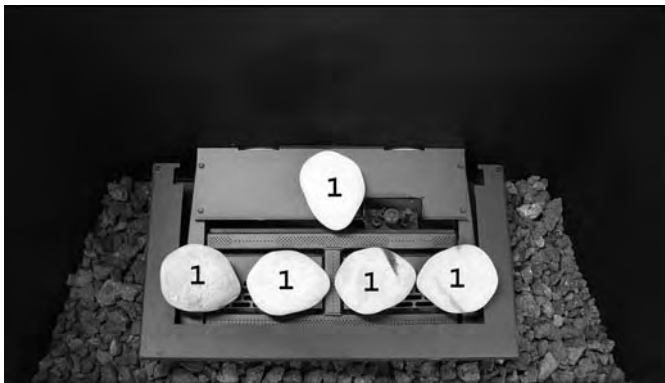

STEP 5: Place rocks #1 onto the burner as shown.

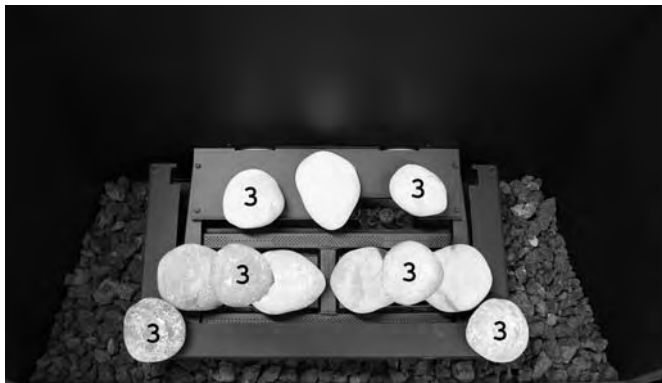

STEP 6: Place rocks #3 onto the burner as shown.



STEP 7: Place rocks #4 onto the burner as shown.



STEP 8: Place rocks #6 onto the burner as shown.



STEP 9: Place remaining rocks #4 and #6 into position as shown.



Finished Rock F2 Setup

Placement of rocks for steps 8 and 9 can be random.

Do not place any of the rocks directly over the burner tubes.

MQROCK1 / MQRSP1 Setup for Model HBZDV4736



WARNING: Failure to position the parts in accordance with these diagrams or failure to use only parts specifically approved with this appliance may result in property damage or personal injury.

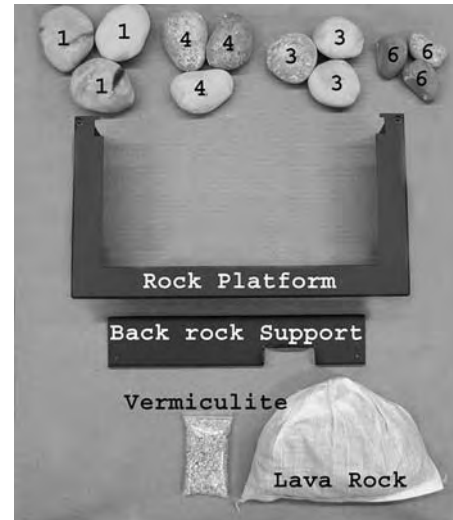

PARTS LIST: Rock #1 - 5 pieces; Rock #3 - 6 pieces; Rock #4 - 10 pieces; Rock #6 - 9 pieces.

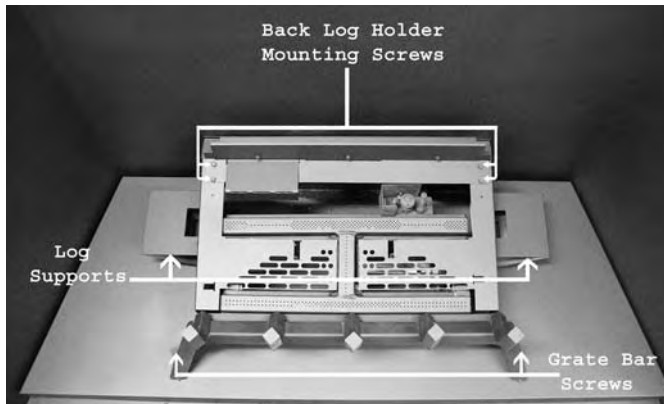

STEP 1: Remove the back log holder, log supports, and the grate bar. Replace/reinstall the 2 screws from the grate bar.

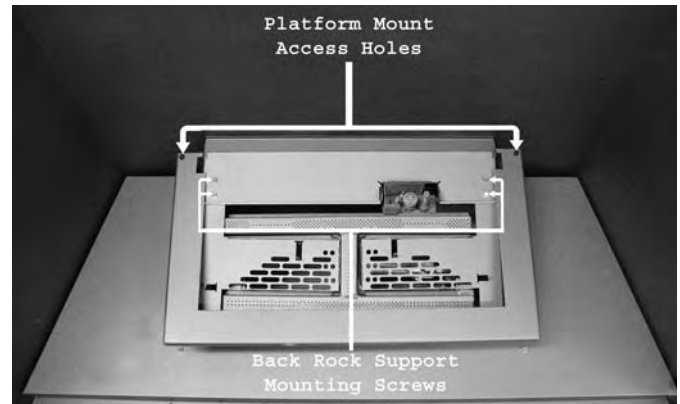

STEP 2: Attach the back rock support using the existing screws from the back log holder. Using the platform mount access holes, attach the rock platform as shown.



STEP 3: Fill around the rock platform with lava rock. Sprinkle vermiculite over top of the lava rock. **Do not place lava rock or vermiculite on top of the burner tube.**



STEP 4: Place rocks #1 onto the burner as shown. **Do not place rocks directly onto the burner tubes.**

MQROCK1 / MQRSP1 Setup for Model HBZDV4736

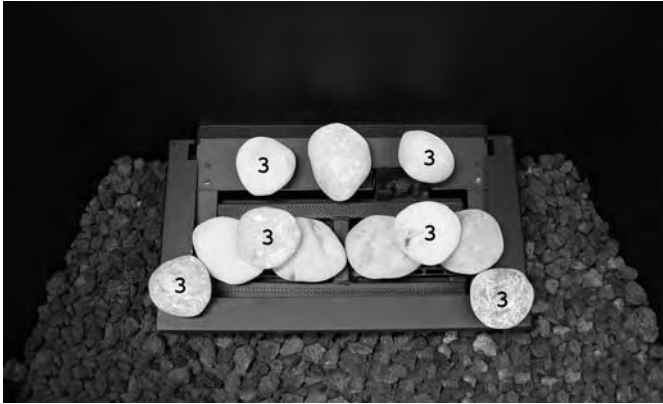

STEP 5: Place rocks #3 into position as shown. **Do not place rocks directly onto the burner tubes.**



STEP 6: Place rocks #4 into position as shown.



STEP 7: Place rocks #6 into position as shown.



STEP 8: Place remaining rocks #4 and #6 into position as shown.



Finished Rock F1 Setup

Never place any of the rocks directly onto the burner tubes.

Note: If flame impingement on the rocks causes sooting, you may have to move or remove one or more rocks. Do not place rocks directly over top of the burner tube.

Accessories for Skyline, ZDVRB3622, & ZRB46 Ribbon Burner Units

ACCESSORY ITEM	MQRB3632	MQRB4236	ZDVRB3622
White Glass MQG5W	Yes / 5LB MAX	5LB Bag c/w Unit	MQ Dealer Only
Bronze Glass MQG5C	Yes / 5LB MAX	Yes / 5LB MAX	5LB Bag c/w Unit
Cobalt Blue Glass MQG5A	Yes / 5LB MAX	Yes / 5LB MAX	MQ Dealer Only
Black Glass MQG5B	Yes / 5LB MAX	Yes / 5LB MAX	MQ Dealer Only
MQROCK2	Yes	Yes	MQ Dealer Only
MQROCK3	Yes	Yes	MQ Dealer Only
MQRBD1	Yes	Yes	MQ Dealer Only
MQSTONE	Yes	Yes	MQ Dealer Only
MQEMBER	Yes	Yes	MQ Dealer Only
ULK2	Yes	Yes	Yes



Use of any other glass can alter the performance of the unit and is not covered under warranty.

Discoloration of glass media may occur if placed on the burner, this is not covered under warranty.

• **GLASS (MQG5W, MQG5C, MQG5A, MQG5B)** This media **MUST** be used; evenly spread the glass embers onto the false bottom and burner. Ensure the glass embers do not excessively overlap as this will affect the flame pattern. Use care when placing glass embers near the pilot area so as not block or have the glass fall over the crossover holes from the pilot to the burner, as delayed ignition can occur.

The following types of glass are approved:

• **½” Ember Glass Material from American Fireglass.**

Maximum amount: Natural Gas is 5 lbs, Propane units 5 lbs.

• **Liquid Glass from Firegear.**

Maximum amount: Natural gas is 5 lbs, not recommended for Propane appliances.

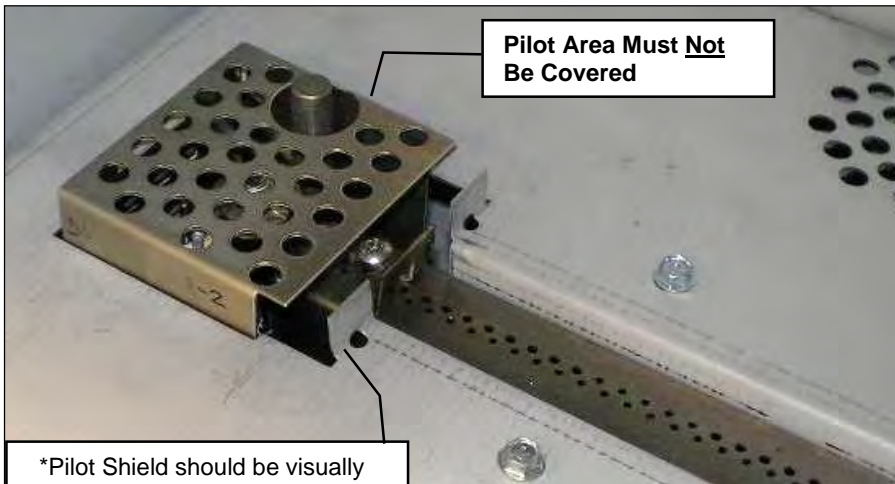

Pilot Area Must Not Be Covered

*Pilot Shield should be visually inspected monthly for signs of deterioration due to flame exposure. Replace if necessary.

⚠ **WARNING**

- Pilot Area Must Not Be Covered, as delayed ignition can occur.
- Do not change or substitute the glass ember material provided with this fireplace. If replacing, use only replacement glass embers available from your local authorized dealer.

Pilot Area Must Not Be Covered

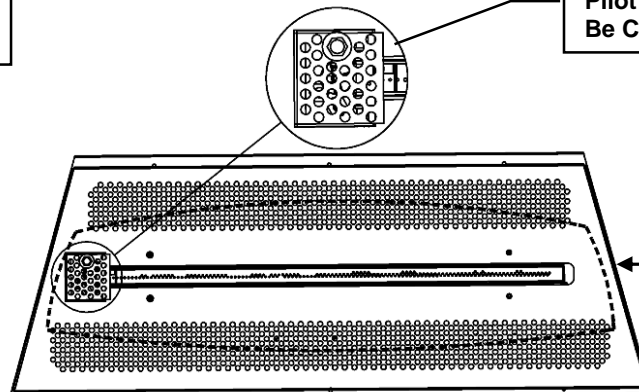

Glass Ember placement for ZDVRB3622 & MQRB4236:
Leave 3-4 rows of perforations uncovered at the front and back of the false bottom. Covering all the perforations at the back may cause flame to pull backward.

⚠ NOTE: Glass Media must be evenly spread over the Burner and False Bottom as described on last page before Rock / Stones / and Log Accessories are placed.

- **MQROCK2, MQROCK3, MQRBD1** - Place rocks randomly onto False Bottom. Be careful not to cover any part of the Burner Tube as sooting may occur.

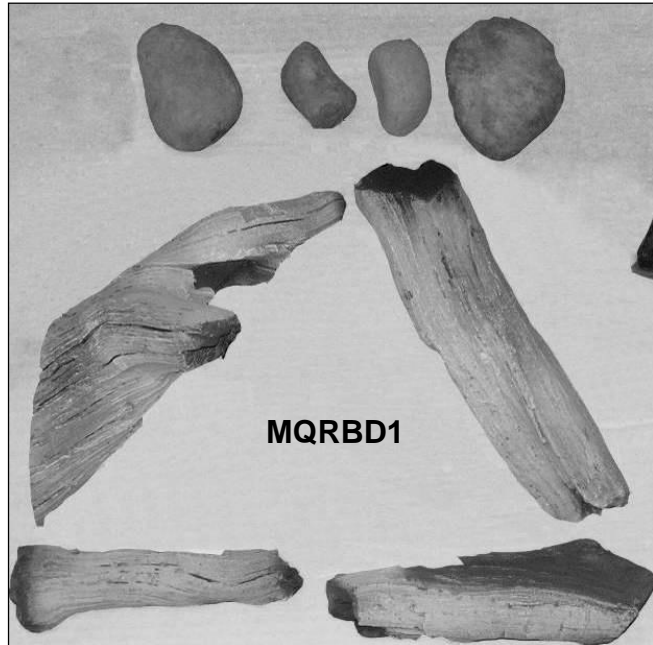
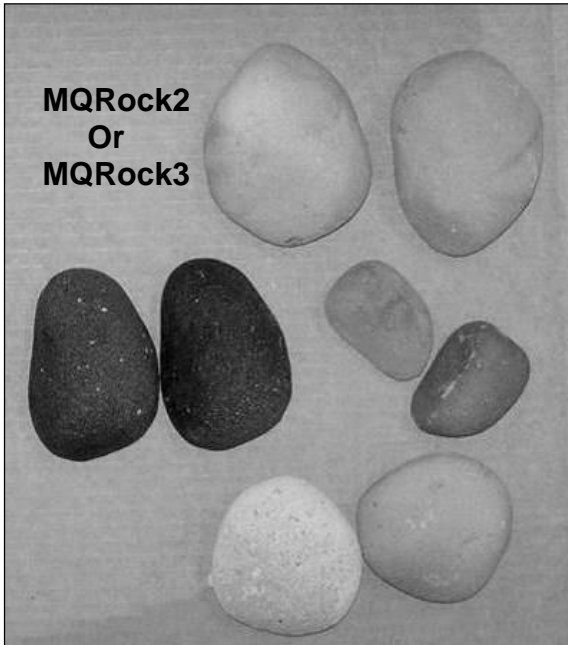

⚠ NOTE

- Pilot Area Must Not Be Covered, as delayed ignition can occur.
- Do Not Cover any part of the burner tube with rocks or logs as sooting may occur.
- In some positions, Logs can cause flame pattern to roll backward, causing sooting. If this occurs, re-position Logs.

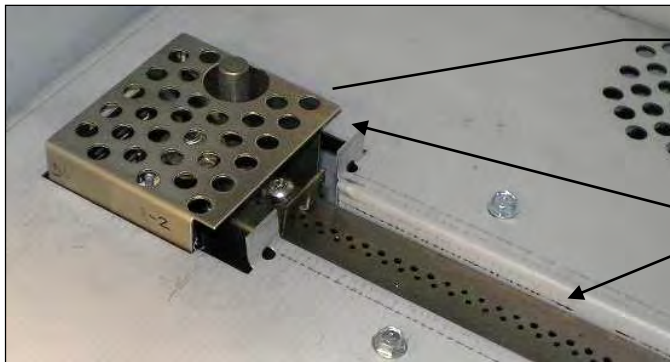

*Pilot Shield should be visually inspected monthly for signs of deterioration due to flame exposure. Replace if necessary.

Burner Tube & Pilot Area Must Not Be Covered.

- **MQ STONE DECORATIVE STONE SET**- Place Stones onto False Bottom and Burner Tube randomly. Do Not stack or overlay when placing on Burner Tube. Do Not cover Pilot Area. Not all stones will be used on some models.
- **MQEMBER**- Place these glowing ember chunks randomly. Embers may be used with or without other accessories.
- **ULK2 UNIVERSAL LIGHT KIT (Optional Accent Lighting Kit)**- See separate installation page.

ULK2 Universal Light Kit (Optional Accent Lighting Kit)

For the Skyline Series (MORB3328, MORB3632, MORB4236) and Kingsman ZDVRB3622

Please follow the current ANSI/NFPA 70 National Electrical Code in the USA and CAN/CSA C22.1 Canadian National Electrical Code in Canada.

Contents of Kit:

- [2] 12V Halogen Lamps
- Lamp Plate with Insulated Studs & wiring
- 12VAC Transformer with 3 prong plug & wire connectors
- Light Switch & Cover Plate c/w10ft wire

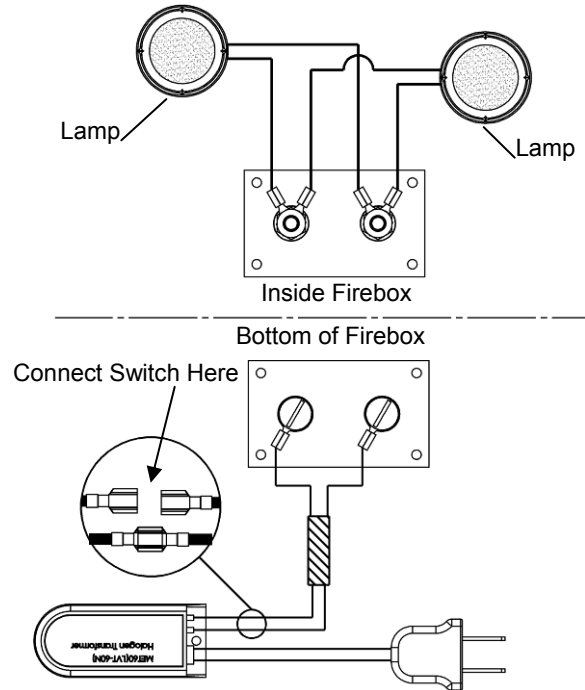
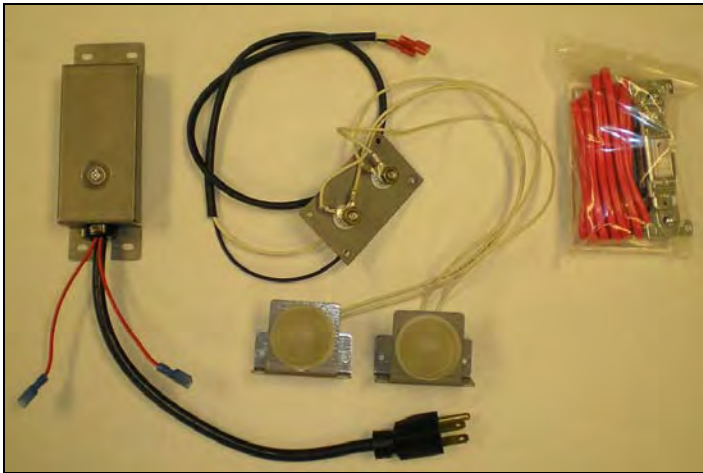

INSTALLATION:

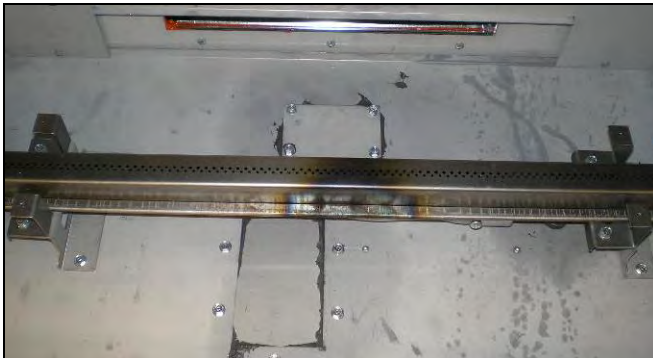

STEP 1: Remove false bottom to expose burner tube. Remove burner tube and cover plate as above. Remove old sealant from opening.

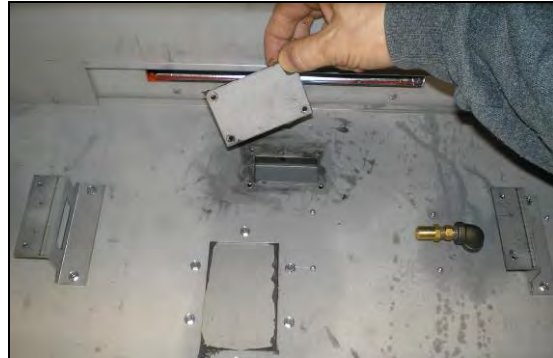

STEP 2: Insert lamp wires through access hole in firebox as above. Apply new sealant (Mill-Pac). Secure Lamp Plate with screws.

MQRB3328, ZDVRB3622, & MQRB4236

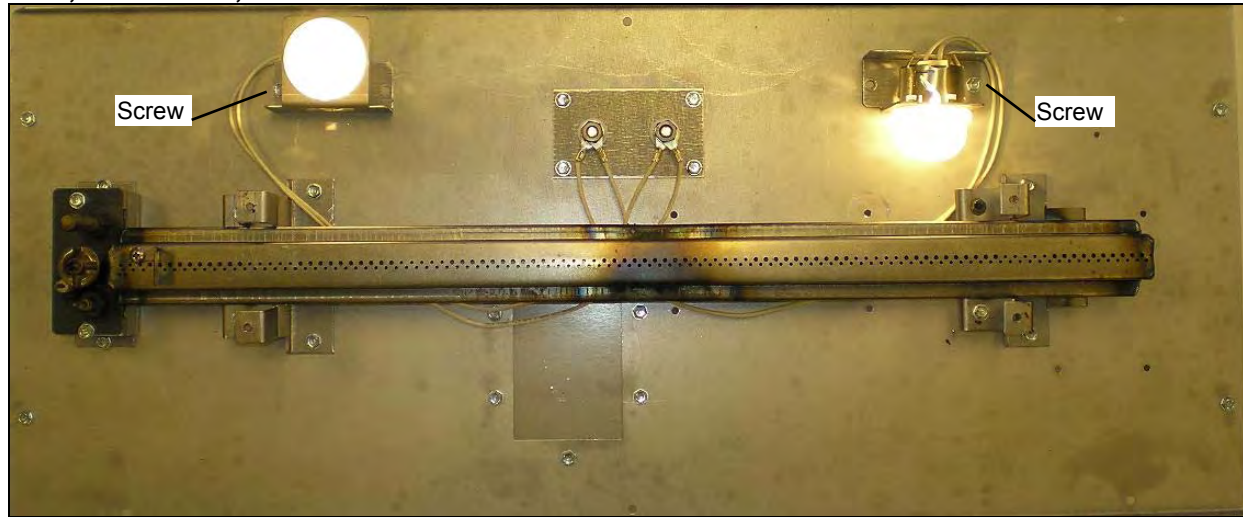

MQRB3632

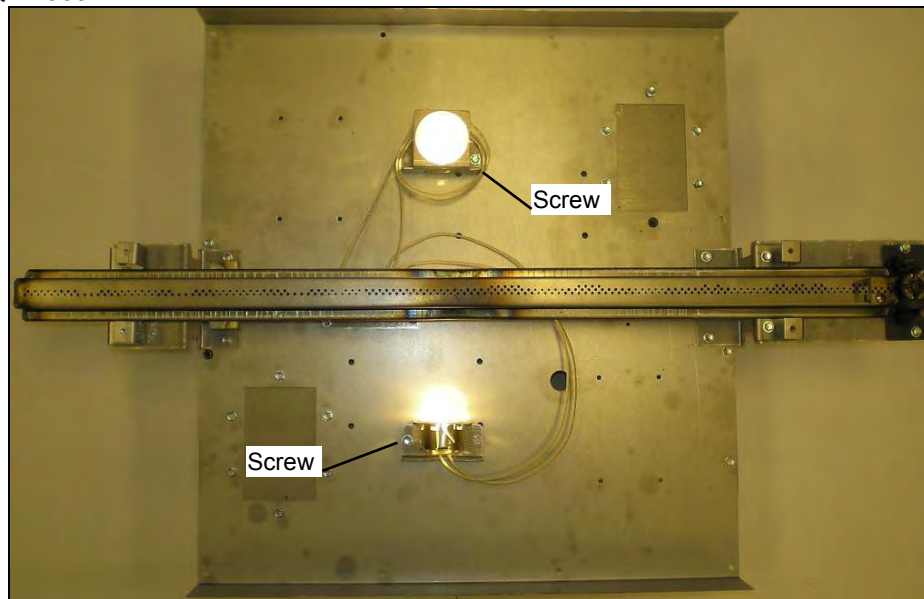

STEP 3: Place Lamps in position in firebox. Attach to fireplace with a single screw at the locations shown above for each unit. Lamps can be placed facing upward or sideways. Replace burner tube and false bottom, along with pilot shield.



STEP 4: Connect switch wires between lamp wire and transformer (see schematic). Connect remaining lamp wire to transformer. Transformer can then be plugged in and the housing fastened to the bottom of the fireplace.



Glass may be used to cover perforations in false bottom

IPI Electronic Ignition System

Overview

The IPI system is an advanced burner controller that provides you with the option of having either a Standing-Pilot, or an intermittent igniting system. This alternating mode is controlled by the CPI/IPI Switch (Continuous Pilot Ignition/Intermittent Pilot Ignition) located on the IPI System Box. The difference between a Standing-Pilot and an Intermittent-Pilot is in whether the pilot stays lit or shuts off:

In Standing-Pilot, the pilot assembly is lit by the IPI Main Module and continues to stay lit until 1) the CPI/IPI Switch is switched to the IPI position; 2) a loss of electrical power (battery and AC source), 3) the flame sensor loses its signal, 4) the fuel supply discontinues, or 5) the IPI Main Module malfunctions.

In the Intermittent-Pilot mode, the pilot shuts off when the appliance is not in use. The advantage of this mode is that fuel is not consumed when the fireplace is not operating.

NOTE: In some jurisdiction, Intermittent-Pilot is required. That means the pilot cannot remain lit when the appliance is not operating.

Components

The core of the IPI system is the Main Module and the IPI Valve. With these two components the system is able to operate a gas fireplace. There are also other components available to complement the IPI system.

IPI System Cover: Is essential in keeping the components at their proper operating temperatures. **DO NOT OPERATE THE APPLIANCE WITHOUT THIS COVER.**

Modulating Servo Motor: Is an add-on valve component that permits HI/LO functionality to be controlled by the remote. Contrary to this feature is a Manual HI/LO Control Knob. The Modulating Servo Motor requires the Remote system to be present.

Backup Battery Pack: This component permits the IPI system to operate without the need for an external AC Adapter power source. The advantage to using the battery backup is that in the case of a power failure, the appliance is still

NOTE: In certain instances the IPI Main Module requires resetting. This can occur if the system is unable to ignite the pilot or the main burner in the allotted time period. The IPI is programmed to lockout all commands. To reset this lockout you must deplete the system of all electrical power. This means to remove the batteries from the Battery Pack, remove the batteries from the Remote Receiver (if applicable), and disconnect the AC Adapter from the system. Leave the power off for approximately 25 seconds to clear its lockout.

operable.

Remote Receiver: This component provides the capability of controlling the appliance with a wireless remote transmitter. There are two switches to note on the receiver module:

The first switch on the Remote Receiver module is a 3-position slide switch. This switch is used to either manually turn the main burner ON, activate the receiver to begin communication with the transmitter, or turn the main burner completely OFF. The position of the slide switch designates these functions respectively.

The second is the small round pushbutton [PRG] used for programming the receiver to respond to a designated remote. Therefore to program the system ensure that the transmitter is first turned OFF. Then, ensure that there is sufficient electrical power going to the Receiver module and a fresh set of batteries in the transmitter. Now switch the

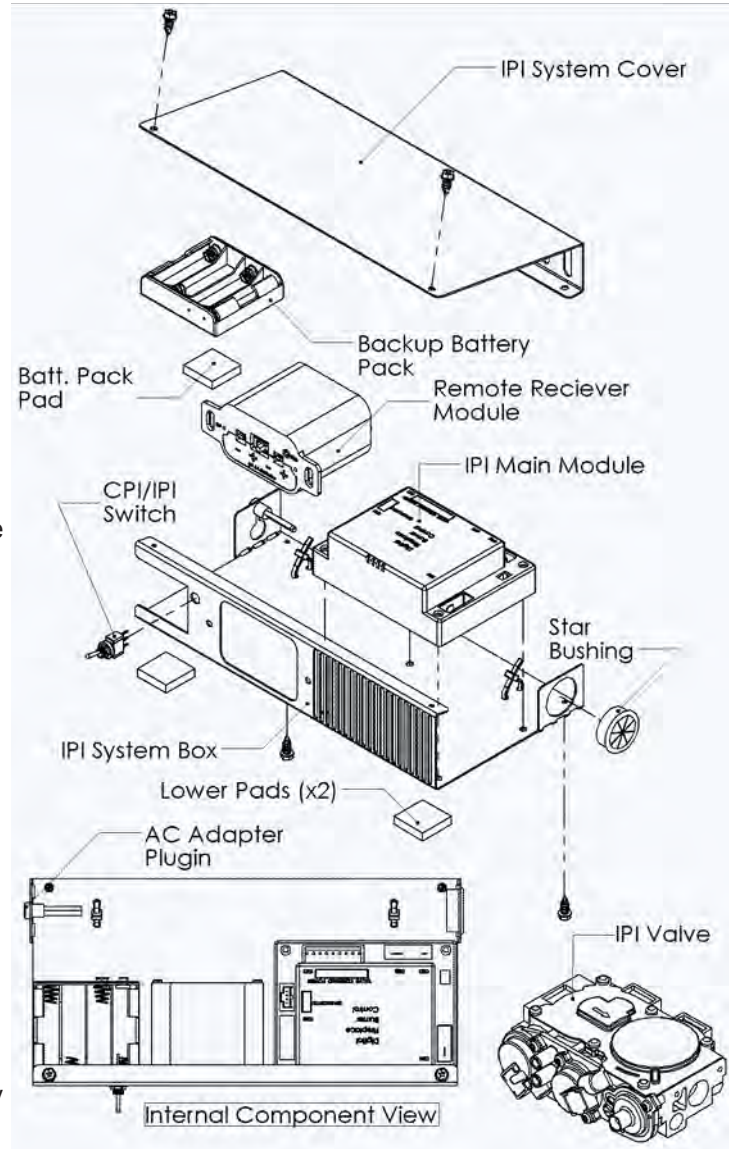

the slide switch to the middle [REMOTE] position and then push the small pushbutton to begin programming. Bring the transmitter close to the receiver and then press the power button [R] on the transmitter. An audible beep will sound to indicate the system is programmed and ready to be used.

NOTE: The Remote Receiver module can also be located outside of the appliance to a maximum of 6ft away installed in a certified deep wall switch electrical box (2-3/4" depth). For this configuration an extension wiring harness (P/N: 1001-P904SI) is required.

Electrical Supply in Series: The entire IPI system can be powered by a single power source (i.e. by the AC Adapter). This is advantageous if you do not want to supply extra batteries. To achieve this simply connect the AC Adapter into the Remote Control wiring harness instead of the main IPI harness. From the Remote wiring harness, use its male plug-in connector and connect it to the female plug-in in the main IPI harness. Now the circuit is complete. So the way it works is that electrical power is supplied to the Remote Receiver module and then proceeds to the Main IPI module. Furthermore, note that a Backup Battery Pack is not required in this configuration. Instead, batteries in the Remote Receiver act as the backup supply.

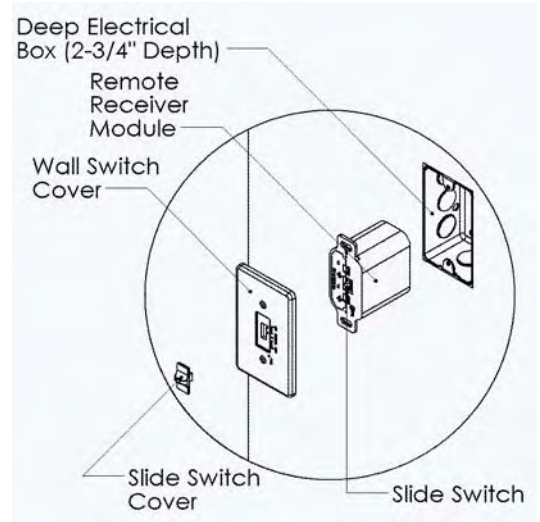

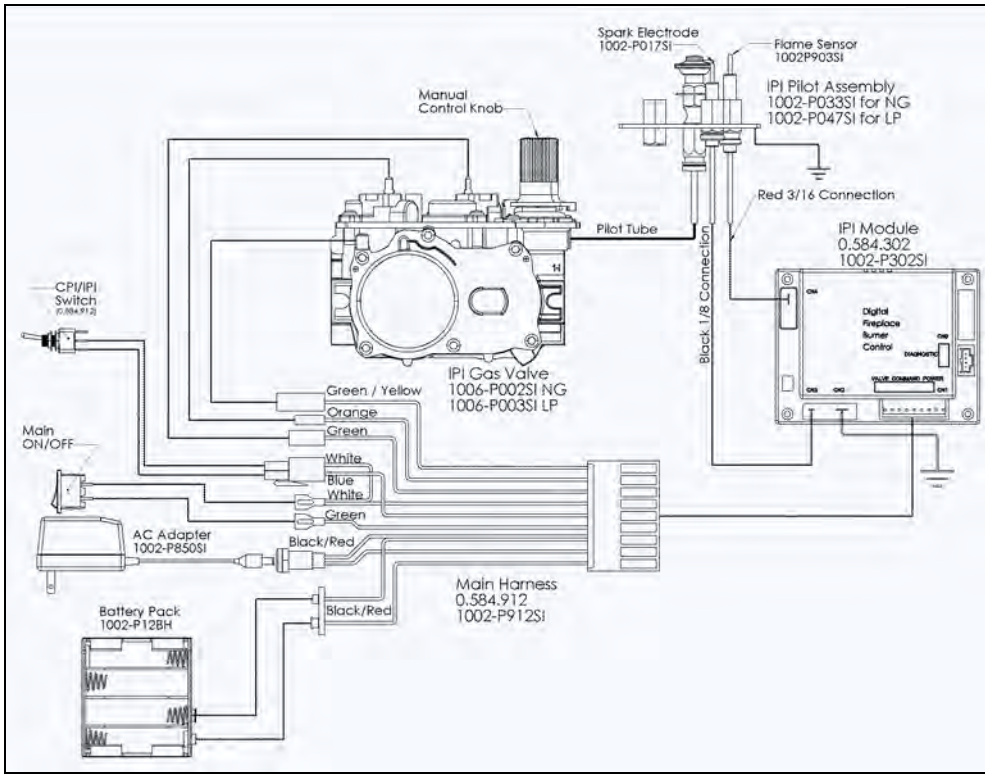

Configuration #1: Basic manual HI/LO and manual ON/OFF capabilities.

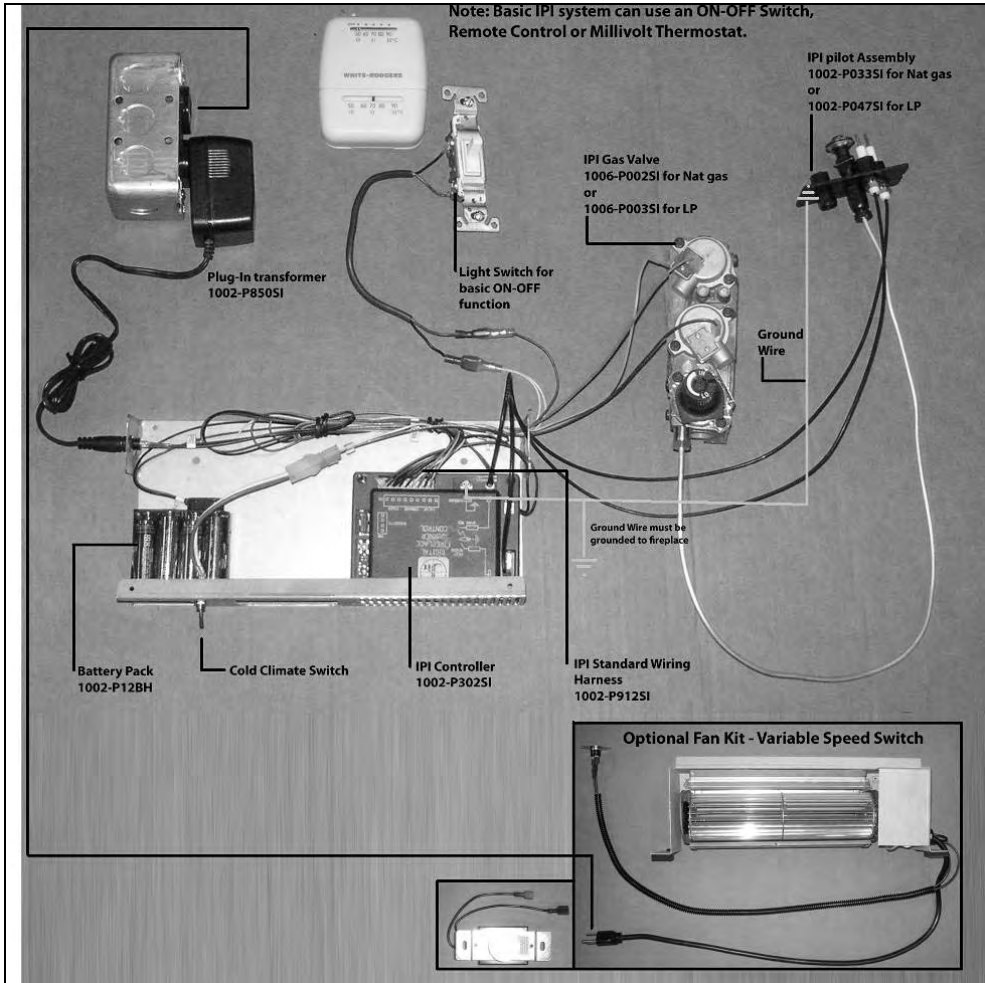

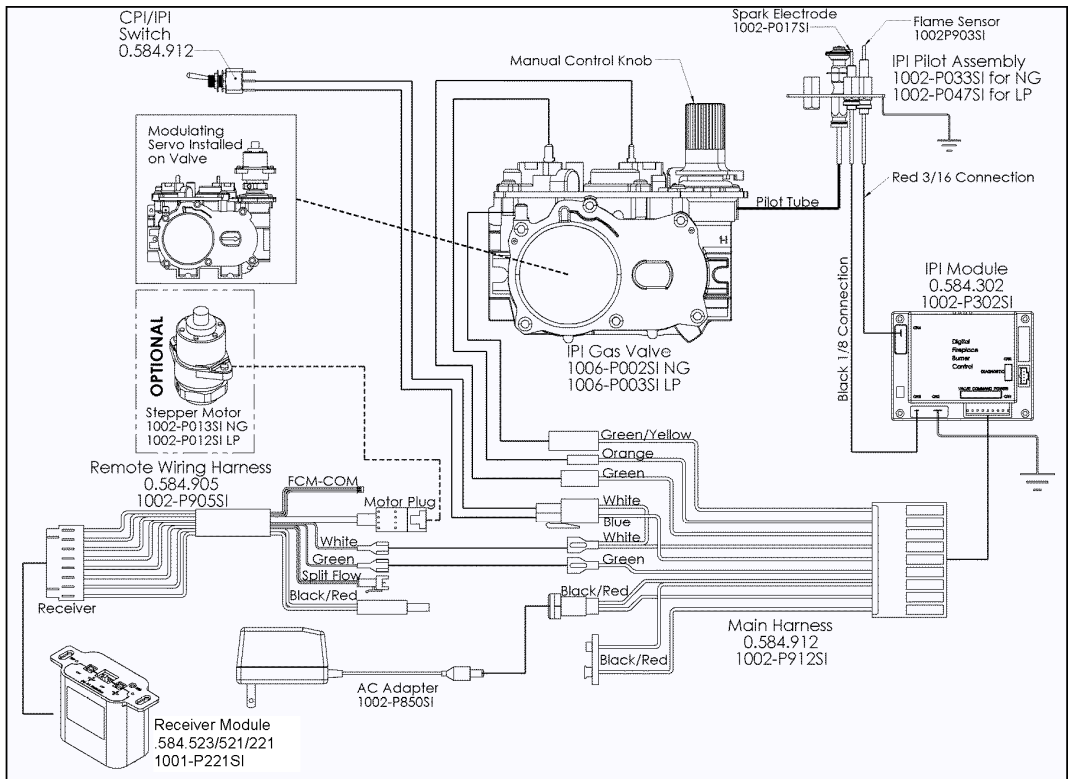

Configuration #2: Remote ON/OFF and manual HI/LO capabilities. **OPTIONAL:** For units with remote HI/LO capabilities, a modulating servo is required to be installed on the valve. The connectors to this servo must be connected to the Remote Harness as shown in the figure above.

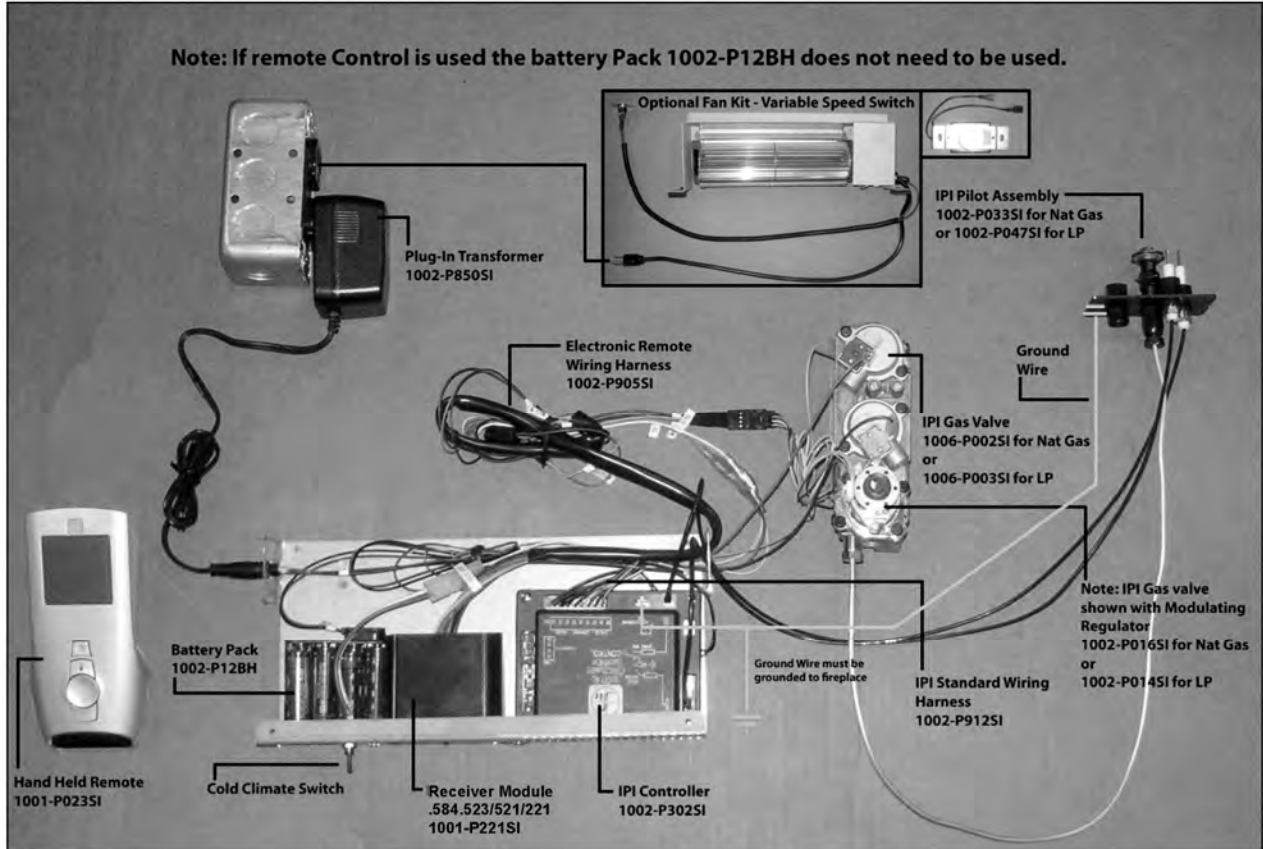

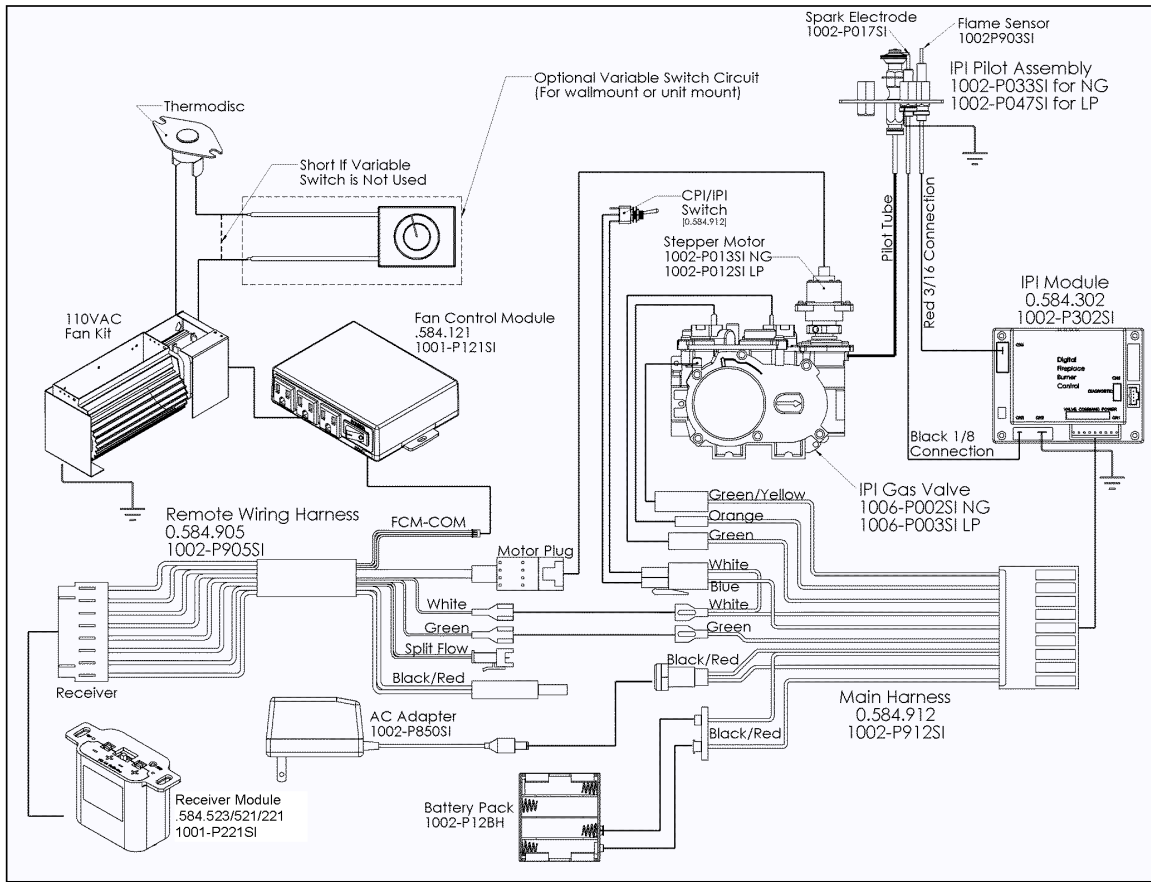

Configuration #3: Remote ON/OFF, variable HI/LO, and fan capabilities. Refer to the fan installation/removal section for fan installation.

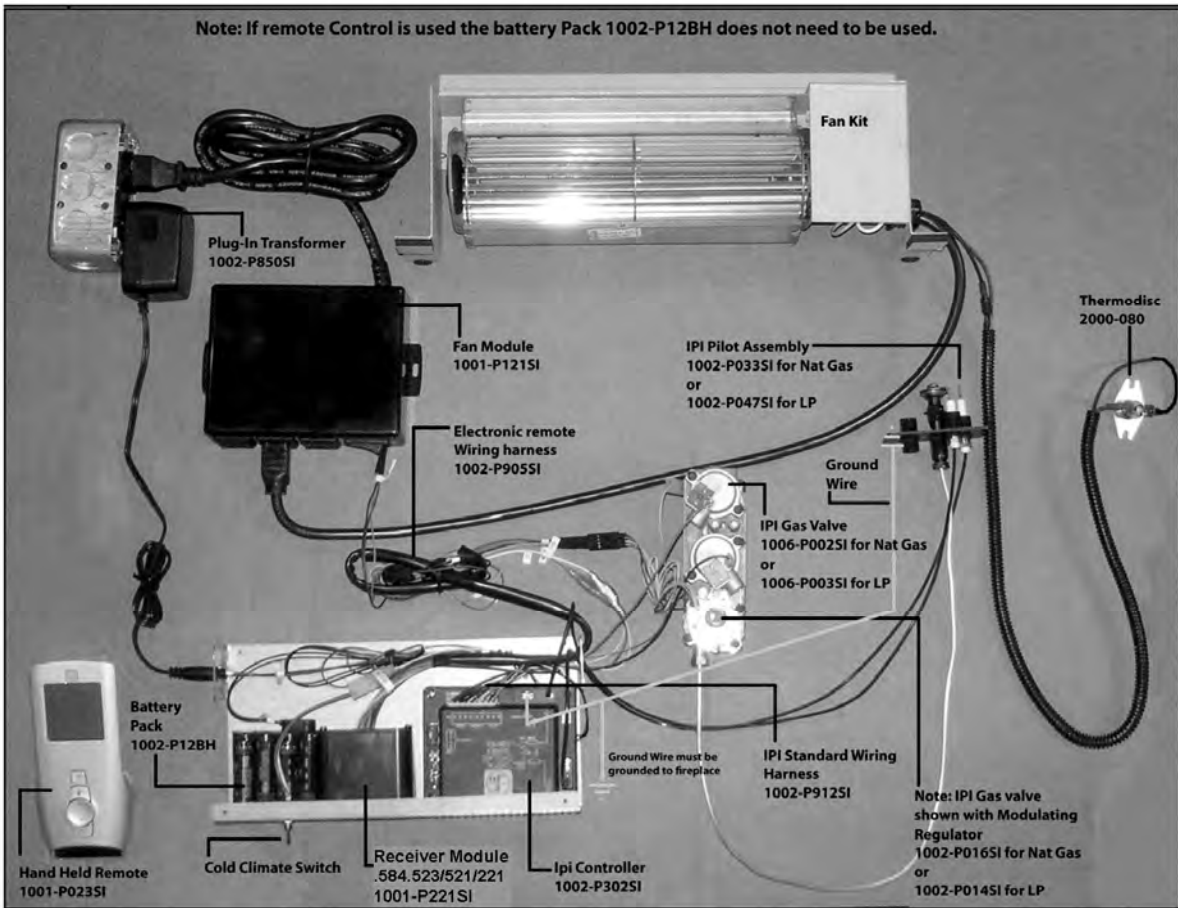

IPI Lighting Instructions



WARNING

1. If you do not follow these instructions exactly, a fire or explosion may result causing property damage, personal injury or loss of life.
2. Always light the pilot whether for the first time or if the gas supply has ran out with the glass door opened or removed.

FOR YOUR SAFETY READ BEFORE LIGHTING



- A. This fireplace is equipped with an ignition device which automatically lights the pilot. Do not try to light by hand.
- B. Before operating smell all around the fireplace area for gas and next to the floor because some gas is heavier than air and will settle on the floor.
- C. Do not use this fireplace if any part has been under water. Immediately call a qualified service technician to inspect the fireplace and replace any part of the control system and any gas control which has been under water



WHAT TO DO IF YOU SMELL GAS

- | | |
|--|--|
| <ol style="list-style-type: none">1. Turn off all gas to the fireplace.2. Open windows.3. Do not try to light any appliance.4. Do not touch any electric switch; do not use any phone in your building. | <ol style="list-style-type: none">5. Immediately call your gas supplier from a neighbor's phone. Follow the gas supplier's instructions.6. If you cannot reach your gas supplier, call the fire department. |
|--|--|

LIGHTING INSTRUCTIONS

1. STOP! Read the above safety information on this label.
2. Remove batteries from Receiver and/or Battery Backup Pack.
3. Turn off all electric power to the fireplace.
4. This fireplace is equipped with an ignition device which automatically lights the pilot. Do not try to light the pilot by hand.
5. Open the glass door.
6. Turn manual shutoff valve clockwise  to OFF position (located behind the access panel).
7. Wait five [5] minutes to clear out any gas. If you smell gas including near the floor, STOP! Follow "B" in the above safety information on this label. If you don't smell gas go to the next step.
8. Turn manual shutoff valve counter-clockwise  to ON position.
9. Close the glass door.
10. Turn on all electric power to the fireplace, and re-install batteries into the Transmitter/Receiver and/or Battery Backup Pack.
11. Turn ON the switch that operates the Main Burner. If using a Remote Control refer to Remote Control Operation Manual for activation.

TO TURN OFF GAS

1. Turn OFF all electric power to the fireplace if service is to be performed, including removing batteries from the Remote Transmitter/Receiver and/or Battery Backup Pack.
2. Access door inside the firebox must be removed to access the manual shutoff valve.
3. If alternate shut-off valve was installed it can be shutoff instead of going through the fireplace to access the fireplace shut off valve.

Proflame 2- Parts List- Basic System, Parts List, Configuration GTMFL

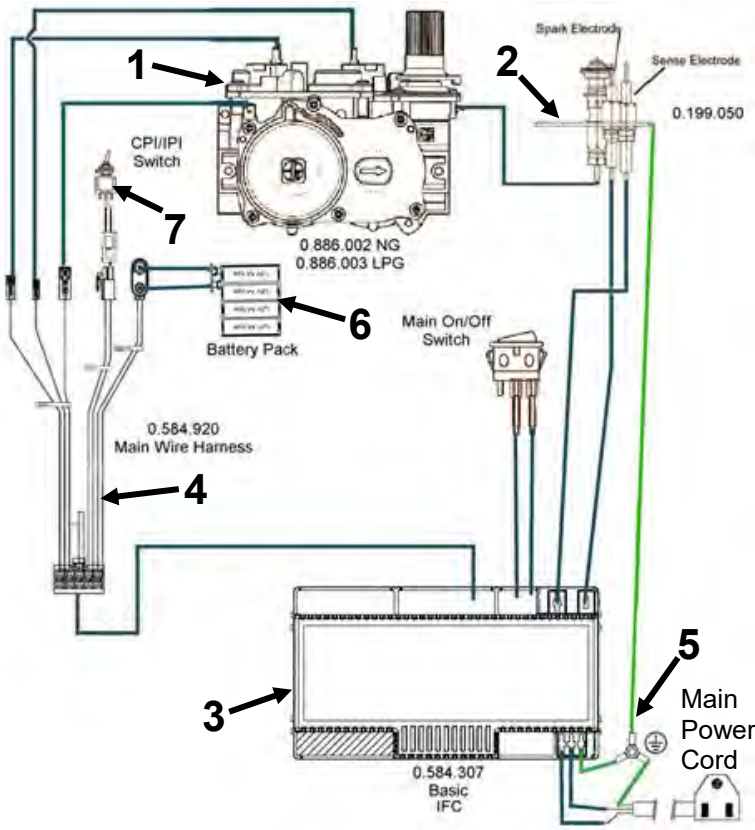

ITEM NO.	PART NUMBER	DESCRIPTION
1.	1005-P001si	IPI Valve NG with Stepper Motor 885.001
	1005-P002si	IPI Valve LP with Stepper Motor 885.001
	1006-P002si	IPI Valve NG Hi / Lo
	1006-P003si	IPI Valve LP Hi / Lo
2.	1002-P033si	Pilot NG IPI 199.059
3.	1005-P325si	Module IPI PF2 584.325
	1006-P307si	Integrated Fireplace Control (Basic) 0.584.307
4.	1006-P920si	Wire harness (Valve, APS connection Jumped, CPI connection) 0.584.920
5.	584-PWR-C	Wire Harness PF2 Main Power Cord
6.	1002-P12BH	Battery Housing
7.	1006-P921si	Wire harness for Split flow 0.584.921 (Not available)
8.	1005-P2SCH	Label – PF2 Schematic Decal
9.	584-X12	Power Vent Harness
10.	584-X4P	Connector- ON/OFF Jumper PF2 651-1766990
11.	584-ACC01-C	Wire Harness PF2
12.	584-X10	Wire Harness PF2 - Accessories
13.	1005-P924si	Harness PF2 IPI 584.924
14.	1005-P042si	Transmitter PF2 584.042
15.	1001-P591si	Battery AAA 658-LR03XWA Transmitter

Proflame 2 System Configuration:

GTMFL SHIPS WITH REMOTE CONTROL TRANSMITTER



NOTE: Fan and / or Light Options are not available on some models of fireplace. **Check with your dealer.**

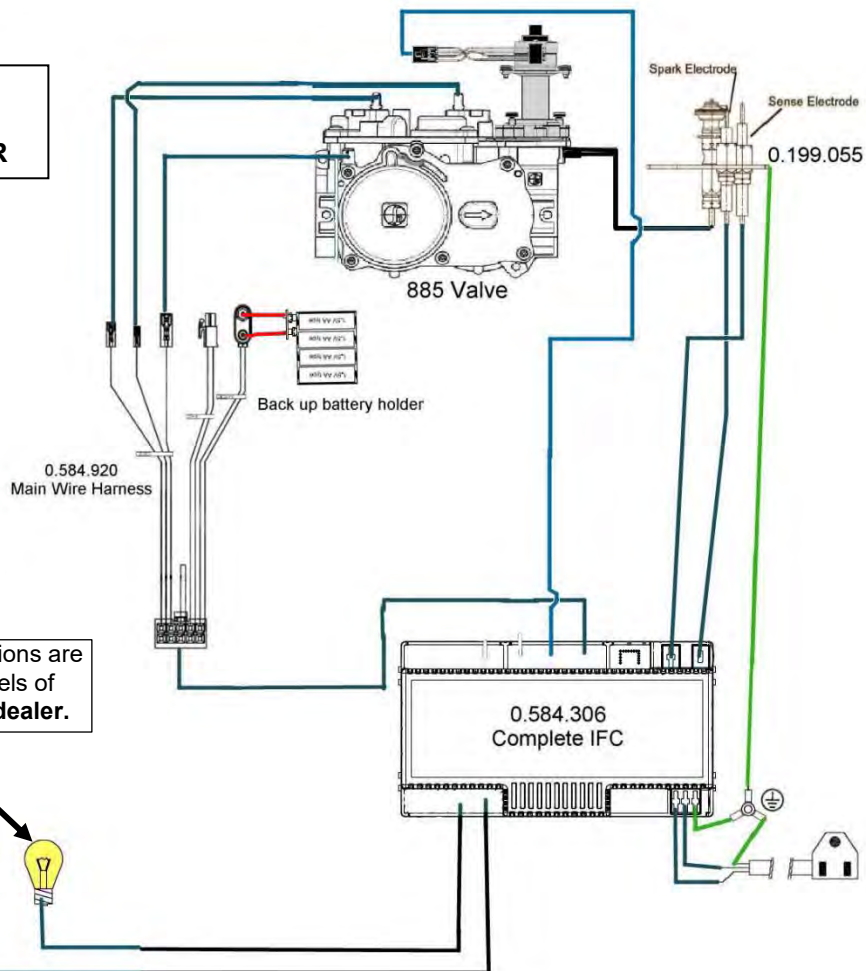

Proflame 2 IFC Module and Remote Control

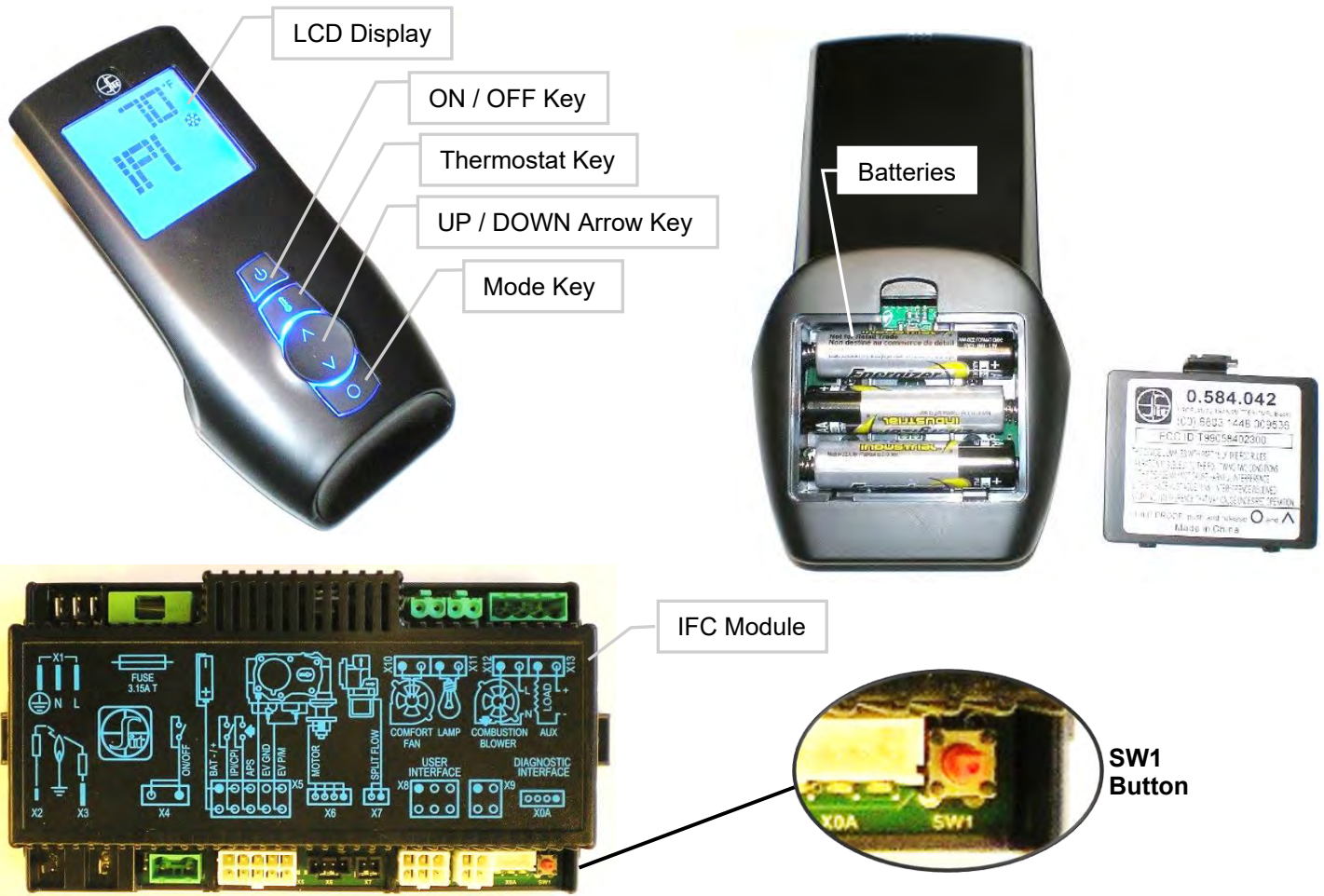

Pairing Remote Control:

- Install the 3 AAA type batteries in the battery bay, located on the base of the Remote Control. Note polarity of the batteries and insert them as indicated.
- Connect the AC power supply to the IFC Module.
- Press the SW1 button on the IFC Module so the IFC will “beep” and a red LED is illuminated to indicate that the IFC Module is ready to synchronize with a Remote Control within 10 seconds. With the batteries already installed in the Remote Control, push the ON button. The receiver will “beep” four times to indicate the Remote Control’s command is accepted.

The system is now initialized.

Resetting Proflame 2 IFC Module for Manual Use

If the transmitter gets misplaced, is broken, or is no longer wanted the PF2 Module can be reset to a manual system. A manual on/off switch or thermostat may be installed at the X4 connector (this connection is Jumped at the factory) no power is required.

The following sequence must be followed to reset the PF2 Module:

- Press the Red **SW1** button until you hear three beeps.

- Within 10 seconds press the **SW1** button again until you hear it beep.
- The PF2 Module may now be turned on/off manually (x4 connector) by a switch (not supplied), the pilot will remain on CPI (continuous pilot ignition) mode, all other functions of main burner, fan and lights will be on the high setting.

Fan Startup and Shutdown Timings:

Fan setting is started with a delay of 5 minutes from the fireplace ignition and stopped with a delay of 12 minutes from the fireplace switching off.

Low Battery Power Detection

When the Remote Control’s batteries are low, a Battery Icon will appear on the LCD display before all power is lost. When the batteries are replaced this icon will disappear.

Battery Backup

The PF2 module is powered by line voltage (AC) with provision of battery backup in case of main power loss. Fans and lighting features will not function with the PF2 Module is powered by battery backup. It is recommended that the 4 x AA batteries are changed before each heating season.

Cold Climates – CPI Setting - Proflame 2 Remote Control

Use the CPI setting during cold weather, otherwise the fireplace may have a hard time starting up and establishing a flame.

The CPI (Continuous Pilot Ignition) setting will keep the firebox and fireplace exhaust vent warm during cold weather. When the firebox and exhaust vent are warm, exhaust gasses will readily flow out of the firebox.

If the firebox and venting are too cold, there is resistance due to the heavy cushion of cold air, and combustion gasses may not rise into the exhaust vent, thus causing the fireplace to cycle or **Lockout** (if this happens see **Lockout Reset Procedures** below).

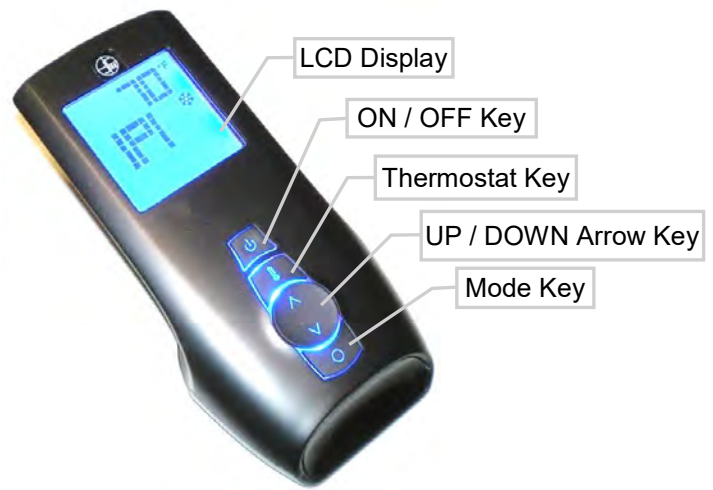

To switch from IPI to CPI Mode:

1. Turn the fireplace OFF using the **ON / OFF Key**.

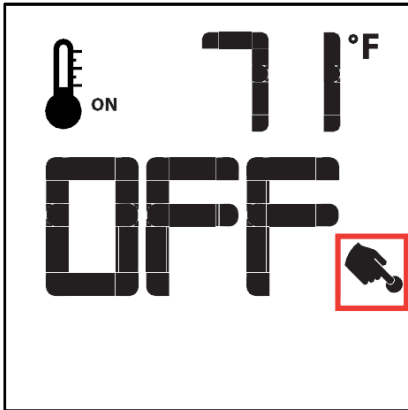

2. Press the **Mode Key**. Display will appear as below.

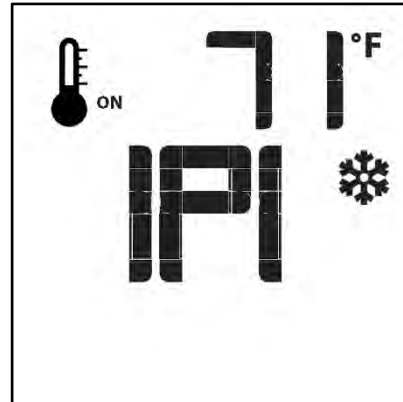

3. Press UP on the **UP / DOWN Arrow Key**. Display will show **CPI**.

The module in the fireplace will beep once to confirm command.

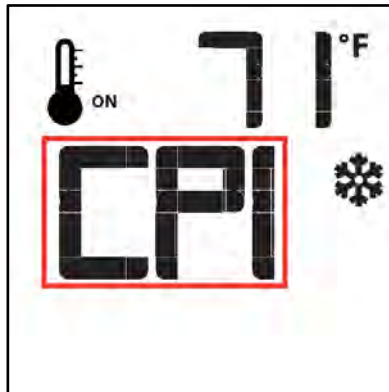

TO RETURN TO IPI (INTERMITTENT PILOT) MODE:

Repeat steps one and two, and then press DOWN on the **UP / DOWN Arrow Key**.

The module in the fireplace will beep once to confirm command.

Lockout Reset Procedures – Proflame 2

If the fireplace has cycled too many times in a short period of time, it will shut down and become unresponsive to any new command. The LED light on the Proflame 2 module in the fireplace will be flashing red.

This condition is a **Lockout** state.

Lockout Reset Procedure:

Disconnect power from the Proflame 2 module in the fireplace for 10 seconds. This includes removing the **backup batteries**.

Once the 10 second interval has passed, reconnect power and reinstall backup batteries. The pilot should now try to light.

If the fireplace does not come on, call your fireplace technician.

Proflame 2 Remote Control

Remote-Flame Control

The proflame has six (6) flame levels. With the system on, and the flame level at the maximum in the appliance, pressing the Down Arrow Key once will reduce the flame height by one step until the flame is turned off.

The Up Arrow Key will increase the flame height each time it is pressed. If the Up Arrow Key is pressed while the system is on but the flame is off, the flame will come on in the high position. (Fig. 7 & 8) A single "beep" will confirm reception of the command.



Fig. 7: Flame Off

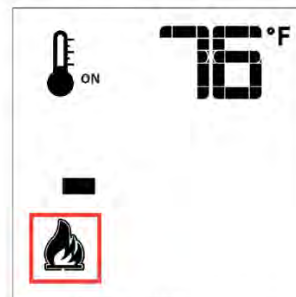

Flame Level 1

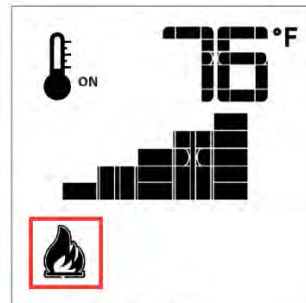

Fig. 8: Flame level 5



Flame Level Maximum

Room Thermostat (Transmitter Operation)

The Remote Control can operate as a room thermostat. The thermostat can be set to a desired temperature to control the comfort level in a room.

To activate this function, press the Thermostat Key (Fig. 1). The LCD display on the Transmitter will change to show that the room thermostat is "ON" and the set temperature is now displayed (Fig. 9). To adjust the set temperature, press the Up or Down Arrow Keys until the desired set temperature is displayed on the LCD screen of the Transmitter.

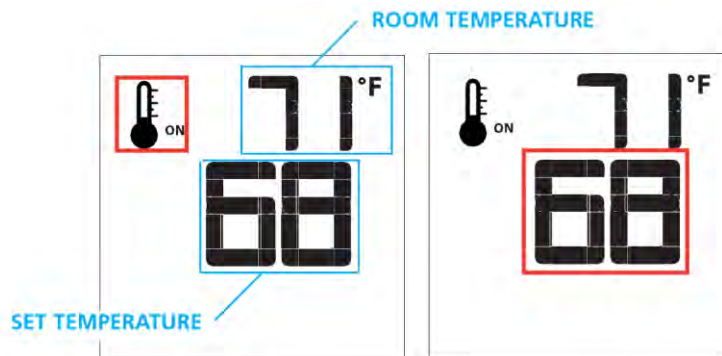

Fig. 9

Fig. 10

Smart Thermostat (Transmitter Operation)

The Smart Thermostat function adjusts the flame height in accordance to the difference between the set point temperature and the actual room temperatures. As the room temperature gets closer to the set point the Smart Function will modulate the flame down. To activate this function, press the Thermostat Key (Fig. 1) until the word "SMART" appears to the right of the temperature bulb graphic (Fig. 11).

To adjust the set temperature, press the Up or Down Arrow Keys until the desired set temperature is displayed on the LCD screen of the Transmitter (Fig. 12).

Note:
When Smart Thermostat is activated, manual flame height adjustment is disabled.

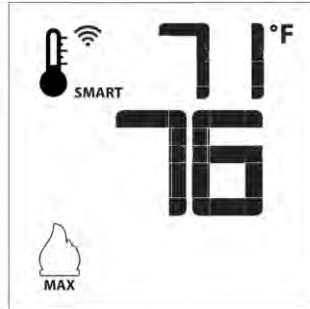

Fig. 11: Smart flame function



Fig. 12

Fan Speed Control

If the appliance is equipped with a hot air circulating fan, the speed of the fan can be controlled by the Proflame system. The fan speed can be adjusted through six (6) speeds. To activate this function use the Mode Key (fig.1) to index to the fan control icon (Fig. 13). Use the Up/Down Arrow Keys (Fig.1) to turn on, off or adjust the fan speed (fig. 14). A single "beep" will confirm reception of the command.



Fig. 13

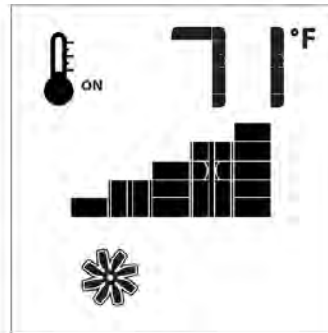

Fig. 14

Remote dimmer control (Light)

The auxiliary function controls the AUX power outlet by the dimmable light control. To activate this function use the Mode Key (fig. 1) to index to the AUX icon (fig. 15 & 16).

The intensity of the output can be adjusted through six (6) levels. Use the Up/Down Arrow Keys (Fig.1) adjust the output level (fig. 16). A single "beep" will confirm reception of the command.

Note:
This function is only available in Room Thermostat or Smart Thermostat Control Mode.



Fig. 15

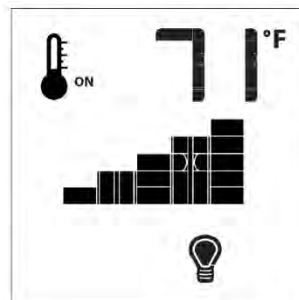
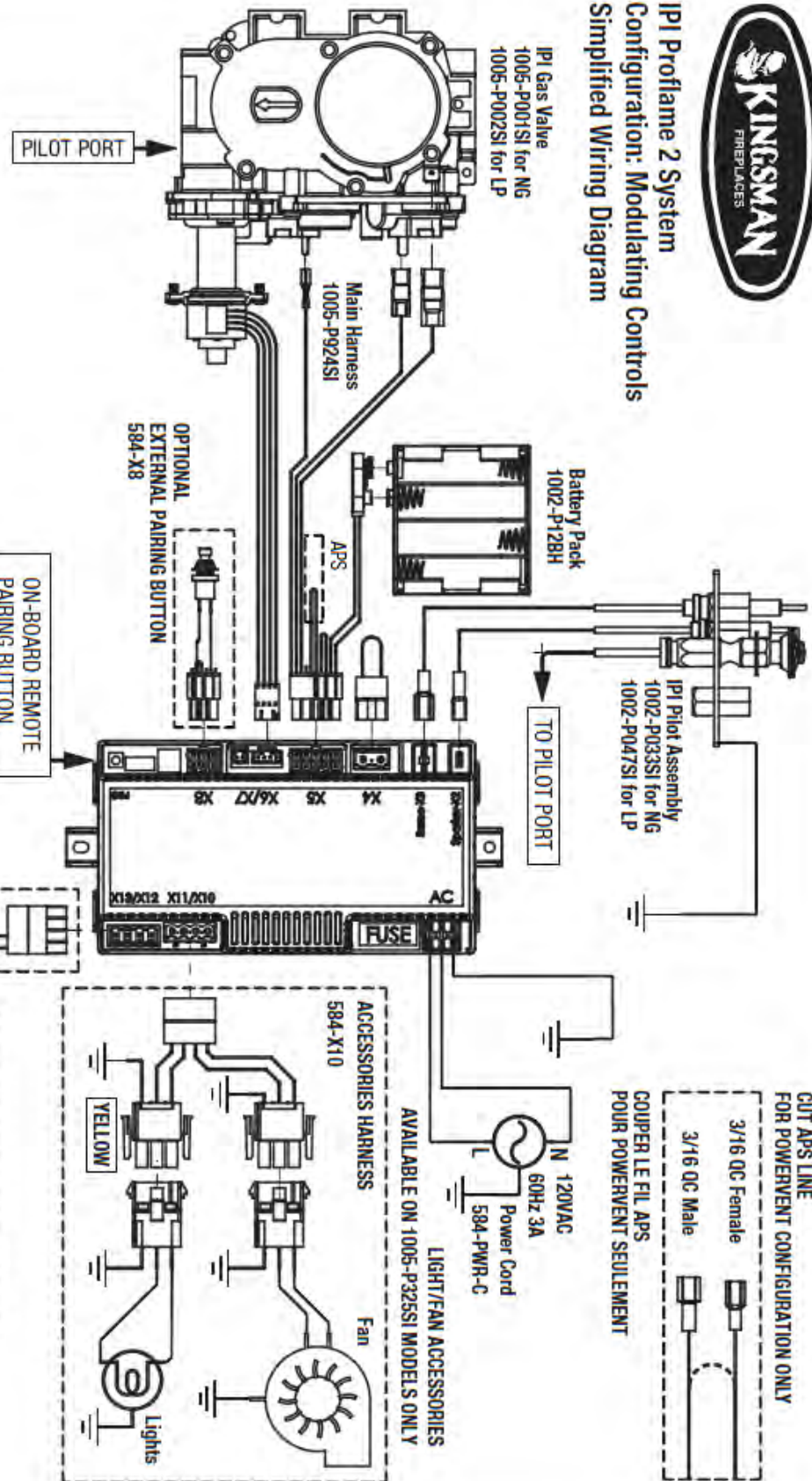

Fig. 16



IPI Prof flame 2 System Configuration: Modulating Controls Simplified Wiring Diagram



Manufactured by: Kingsman Fireplaces
2340 Logan Avenue
Winnipeg, MB R2R 2V3

For use with all Kingsman manufactured IPI Prof flame 2 models, for all types of gas noted on rating plate. Supply 120VAC 60Hz 3A, 6 volts battery backup.

Pour utilisation avec tous les modèles IPI Prof flame 2 fabriqués par Kingsman, pour tous les types de gaz noté sur la plaque signalétique. Voltage d'alimentation: 120VAC 60Hz 3A et 6 volts pour le bloc-piles de secours.

This component should be installed by a qualified service agency.
Cetle composante doit être installée par une entreprise de service qualifiée.

Part #1005-P2SC4

Vent Termination

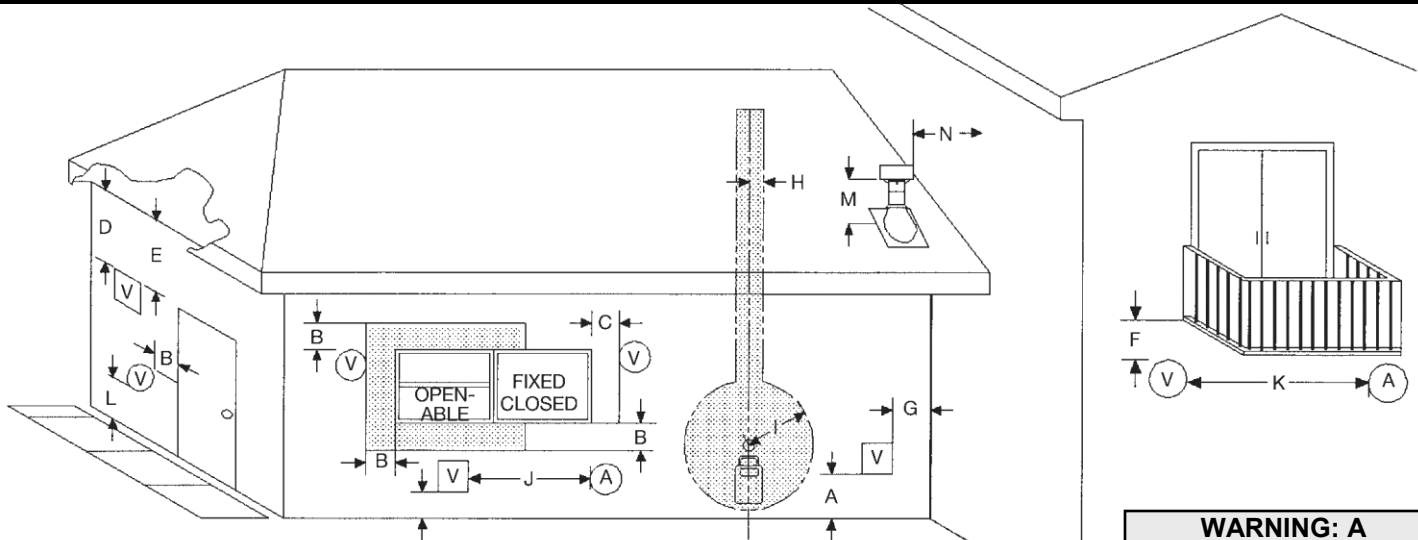

- Area Where Terminal Not Permitted.
- Air Supply
- Measure to edge of the Termination Plate
- Measure to edge of the Round Termination

Notes:

- 1) Clearances are to the edge of the terminal plate. Add 6-3/4" to clearances to arrive at centerline.
- 2) Local codes or regulations may require different clearances.

WARNING: A HORIZONTAL VENT CERTIFIED GUARD (SAFETY CAGE) IS AVAILABLE WHEN REQUIRED BY LOCAL CODES.

- A. Clearance above grade, veranda, porch, deck, or balcony 12 inches (30cm) minimum [1].
- B. Clearance to window or door that may be opened. 12 inches (30cm) minimum for appliances 100 000 Btuh (30 kW) and lower, in Canada. 9 inches [2] (23cm) for appliances 50 000 Btuh and lower, in USA.
- C. Clearance to permanently closed window minimum 12 inches (30cm) recommended to prevent condensation on window, in Canada. 9 inches [2] (23cm) for appliances 50 000 Btu's and lower, in USA.
- D. Vertical clearance to ventilated soffit or vinyl soffit / siding located above the termination within a horizontal distance of 2 feet (60cm) from the center line of the termination. 18 inches (46cm) minimum [5].
- E. Clearance to unventilated soffit 12 inches (30cm) minimum.
- F. Clearance under veranda, porch, deck or balcony 12 inches [1] (30cm) minimum [4].US [5]
- G. Clearance from a perpendicular inside wall or outer corner to the edge of the vent terminal plate is 3" (minimum).
- H. Clearance to each side of center line extended above meter/regulator assembly 3 feet (91cm) within a height 15 feet (4.5m) above the meter/regulator assembly.
- I. Clearance to service regulator vent outlet 3 feet (91cm) minimum [1]. US[5]
- J. Clearance to non-mechanical air supply inlet to building or the combustion air inlet to any other appliance: In Canada, 6 inches (15cm) for appliances ≤10,000 Btuh (3kW), 12 inches[1] (30cm) minimum for appliances >10,000 Btuh (3kW) and ≤100,000 Btuh (30kW), 36 inches (91cm) for appliances >100,000 Btuh (30kW). In the USA, 6 inches[2] (15cm) for appliances ≤10,000 Btuh (3kW), 9 inches (23cm) for appliances >10,000 Btuh (3kW) and ≤50,000 Btuh (15kW), 12 inches (30cm) for appliances >50,000 Btuh (15kW).
- K. Clearance to a mechanical air supply inlet 6 feet (1.8m) minimum [1], in Canada. In USA, 3 feet (91cm) above if within 10 feet (3m) horizontally[2].
- L. Clearance above paved sidewalk or a paved driveway located on public property 7 feet (2.1m) minimum [3].

- M. Clearance above highest point of exit on roof 18 inches (45cm).
- N. Clearance to perpendicular wall 24 inches (60 cm). (Recommended to prevent re-circulation of exhaust products. For additional requirements check local codes.)
- O. A moisture-exhaust duct shall not terminate within 3 ft (1 m) in any direction of a service regulator or fresh-air intake.

NOTE: Clearances are to the edge of terminal plate, add 6-3/4" to clearances to arrive at center line.

NOTE: Local Codes or Regulations may require different clearances.

Termination

It is imperative that the vent termination be located observing the minimum clearances as shown. There must not be any obstruction such as bushes, garden sheds, fences, decks or utility buildings within 24" from the front of the termination plate.

Do not locate termination where excessive snow or ice build-up may occur. Be sure to check vent termination area after snow falls and clear to prevent accidental blockage of venting system. When using snow blowers, make sure snow is not directed towards vent termination area.

Venting terminal shall not be recessed into a wall or siding. If finishing the outside wall with vinyl or wood siding it is recommended that a Siding Shield be installed, Part Number ZDVSSLR.

1. In accordance with the current CSA B149.1, Natural Gas and Propane Code.
2. In accordance with the current ANSI Z223.1/NFPA 54, National Fuel Gas Code.
3. A vent shall not terminate where it may cause hazardous frost or ice accumulations on adjacent property surfaces.
4. Permitted only if veranda, porch, deck, or balcony is fully open on a minimum of two sides beneath the floor.
5. Clearance in accordance with local installation codes and the requirements of the gas supplier.

Note: A vent must not terminate directly above a sidewalk or paved driveway, which is located between two single-family dwellings and serves both dwellings. **THIS DOES NOT APPLY to direct vent, non-condensing appliances in the Province of Ontario.**

General Vent Installation Information

This gas appliance is approved to be vented either through the side wall or vertically through the roof. Only Kingsman Flex(Z-Flex)Venting Kits and components specifically approved and LABELED for this stove may be used. This appliance is also approved for use with Simpson-Duravent Direct Vent system, Ameri-Vent Direct Vent Pipe System, ICC Excel Direct, Metal Fab Sure-Seal DV and Selkirk Direct Temp.

RIGID OR HARD PIPE

When using Simpson Duravent, AmeriVent pipe, ICC Excel Direct, Metal Fab Sure-Seal DV and or Selkirk Direct Temp a Duravent hard-pipe adapter must be used (part # ZDVDFa for fireplaces and part # ZDVdKA for Stoves, Serenity and ZDV3624B). Follow installation instructions provided by Simpson Duravent/AmeriVent/Selkirk Direct Temp, ICC Excel Direct, Metal Fab Sure-Seal DV for installation of pipe and adhere to the clearance to combustibles provided in this manual. Apply a bead of Mill Pac high temp sealant to all joints of pipes, adapters and termination, when using Kingsman Flex(Z-Flex)Venting venting and Simpson Duravent venting.

NOTE: Increase framing depth by one inch when using hardpipe.



WARNING: DO NOT mix parts from different systems unless stated in the manual.

Flex Pipe Venting

Flex pipe is shipped in unexpanded length. When installing pipe expand the lengths. Pipe can be expanded to twice their lengths e.g. 4ft. to 8ft. Fully extend pipe and cut off remaining pipe.

Do not use more than 2 couplers to extend short pipes. Single sections are preferred in an installation attaching at the fireplace and termination.

Place the spring spaces provided approximately every two feet to stabilize 4" flex in the center of 7" flex. When forming bends place spring in bend or before and after. (See Fig. 1).

Horizontal runs require support metal straps every 2 feet. In off set installation support straps should be used to stabilize pipe.

Expand 4" and 7" flex pipe to the point that the 7" protrudes approximately 2 to 3 inches past outer wall and the 4" flex protrudes approximately 2 to 3 inches past the 7" flex. See Fig. 1. Attach the 4" pipe to the termination first and secure with sealant and four screws then attach the 7" flex to the termination with caulking and four screws. Termination may then be moved back to the outer wall and attached to home screwing into the framing. Silicone around termination to waterproof. If siding shield is going to be used attach this using same attaching hole as the top of termination after termination has been caulked for water proofing.

Use Hi Temp Sealant

Apply a bead of mill pac high temp sealant to all joints and use four screws to secure each pipe at fireplace, termination and any joint if joining any sections of pipe.



WARNING: A HORIZONTAL VENT CERTIFIED GUARD (SAFETY CAGE) IS AVAILABLE WHEN REQUIRED BY LOCAL CODES.

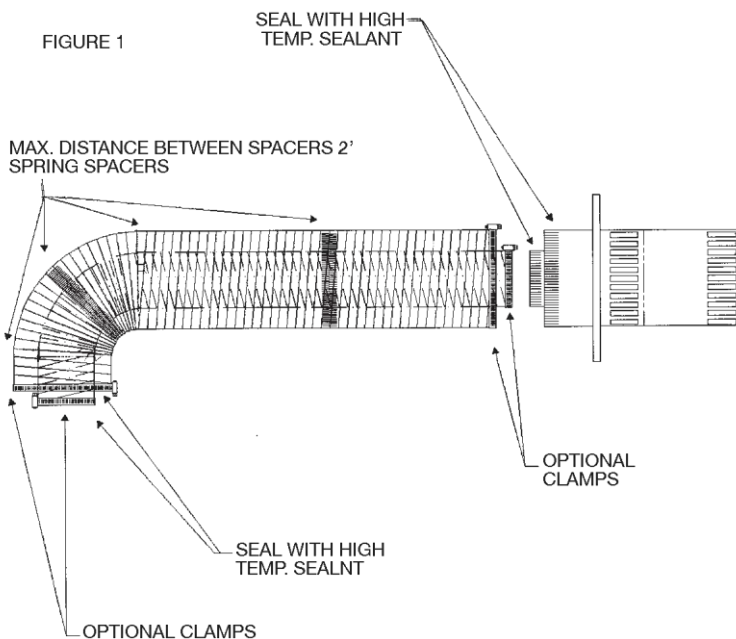

NOTE: It is critical to the proper and safe operation of this fireplace that on all connections the inner liner and the outer casing are both caulked with liberal amounts of sealant. Do not use any kind of tape or silicone other than that recommended in this manual. Mill Pac Sealant

Venting Routes And Components

Since it is very important that the vent system maintain its balance between the combustion air intake and the flue gas exhaust, certain limitations as to vent configurations apply and must be strictly adhered to.

The table showing the relationship between vertical and horizontal side wall venting will help to determine the various vent lengths.

The maximum horizontal run with the 90 degree bend at the fireplace flue outlet is 4 ft/122cm (Figure #1). The maximum horizontal run is 20 ft/6.1 m when the vertical run is 7 ft/2.1m (Figure #2). Note: 1/4" vertical rise is required for every 12" of horizontal run.

The maximum number of 45 degree bends per side wall installation is two (2) in the horizontal run and then you must reduce the length of the horizontal by 18 inches for each 45 degree bend.

The maximum vertical run is 40 ft/12.2 meters.

Special Note: For each 45 degree bend installed in the horizontal run, the length of the horizontal run must be reduced by 18" (45cm). This does not apply if the 45 degree bends are installed on the vertical part of the vent system.

Example: If according to the table, the length of the horizontal run is 10 feet, and two 45 degree bends are required, the horizontal run length must be reduced to 7 feet.

2 additional 90° bends or equals are allowed. The horizontal run must be reduced by 36" per each 90° bend, or 18" per each 45° bend.

Important: Always locate the fireplace in such a way that a minimum of offsets and/or horizontal runs are required. 1/4" vertical rise is required for every 12" horizontal run.

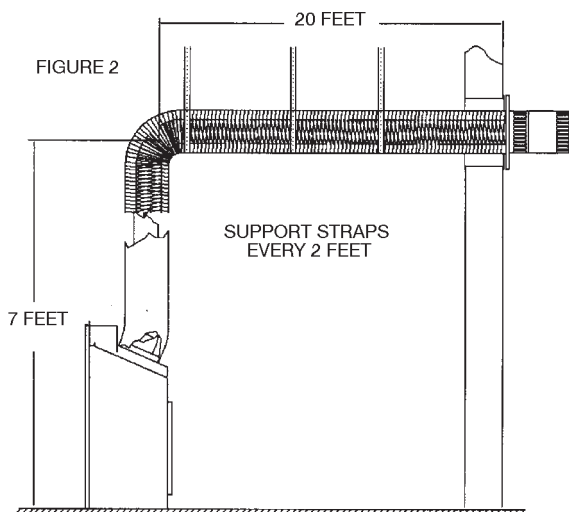
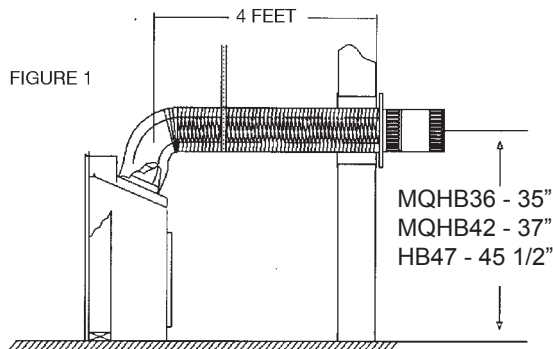

How To Use The Horizontal Vent Table

1. Determine the height of the system and the number of bends required.
2. Having determined the vertical distance determine the maximum horizontal section allowed.
3. Vent table has been established for 90° horizontal/vertical runs. With use of flex pipe distance not having 90° bends will not fall into vent table standards. See Fig. B.

Horizontal Venting Table From Bottom of Fireplace

for venting to a maximum of 40 ft. (12.2 meters)

Total Vertical		Max Total Horizontal	
Feet	Meters	Feet	Meters
4	1.2	5	1.5
5	1.5	8	1.2
6	1.8	12	3.7
7	2.1	20	6.1
8	2.4	20	6.1
9	2.7	20	6.1
10	3.0	20	6.1
11	3.4	20	6.1
12	3.7	20	6.1
13	4.0	20	6.1
14	4.3	20	6.1
15	4.6	20	6.1
16	4.9	20	6.1
17	5.2	20	6.1
18	5.5	20	6.1
19	5.8	20	6.1
20	6.1	20	6.1
25	7.5	15	4.6
30	9	10	3.0
40	12.2	0	0

Example A:

If the vertical dimension from the floor of the fireplace is 6ft, the horizontal run to the wall flange of the vent termination must not exceed 12ft.

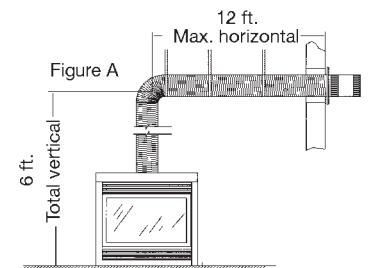

NOTE: The final location of the fireplace must be such that the horizontal vent dimensions fall within those stated on the graph. The Maximum Vertical vent run is 40ft. (12.2 meters).

Important: Minimum clearance between vent pipes and combustible materials is 1 inch (25mm).

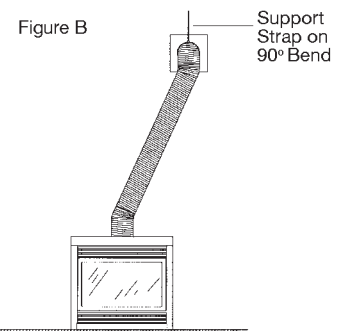

It is recommended for **Propane Horizontal Installations** that the venting should be a minimum of one foot vertical off the flue before the elbow on any horizontal runs of one foot or greater. This allows for cleaner combustion and greatly reduces carboning and cleaning of glass. (Does not apply to Back Flue Models).

Installation Of Side Wall Venting

1. Establish the minimum distance from the bottom of fireplace to centre of vent. Cut a hole through the wall allowing for a 11" x 11" (inside diameter) in combustible walls for wall thimble or an 8" diameter hole in a non-combustible wall (See Figure 1-2-3).
2. Note clearance to combustibles as stated .
3. Select the approximate vent length, precise measurements are not needed as your flex pipe can be expanded to twice its shipped length for ease of installation.
4. To install wall thimble centre over 11" x 11" (inch) framing from both sides of wall and secure. Route flex vent pipe through wall thimble (See Figure 1).
5. Before joining pipes, apply a bead of high temperature sealant (Mill Pac) to end of pipe. First attach the four inch (4") flue pipe to the vent termination with sealant, and secure with 4 screws provided. At this time make sure the spacer springs are attached to the (4") flex pipe as required. Then attach the seven inch (7") pipe by the same method.
6. Mount vent termination and seal to wall using caulking around the wall thimble to weather proof. After installing the vent termination, double check to make sure the pipe extends properly through wall thimble and into vent termination.
7. Before joining pipes to fireplace flue, apply a bead of high temperature sealant (Mill Pac) to end of pipe. First attach the four inch (4") flue pipe to fireplace with Mill Pac sealant to the flue pipe and secure with 4 screws provided. At this time verify that the spacer springs are attached properly to the (4") flex pipe as required. Then attach the seven inch (7") pipe by the same method.
8. Support horizontal pipes every two (2) feet (61 cm) with metal strap bands. Re-check fireplace to make sure it is levelled and properly positioned and secured.
9. Support vertical pipes to maintain a minimum of 1" or greater clearance to combustibles with metal strapping bands.
10. If finishing the outside wall with vinyl or wood siding it is recommended that a Siding Shield be installed, Part Number ZDVSSLR.

Note: Wall Thimble cover combustible wall up to 11" thick.

Note: Venting termination must not be recessed into wall or siding.

MQHBZDV3636

Minimum clearance to combustibles on venting is 1" with the following exceptions as follows:
 Top of horizontal 1 1/2".
 Top of 90 degree elbow in an enclosure 42-43" is 3 1/2".
 Top of 90 degree elbow in an enclosure over 43" is 2 1/2".

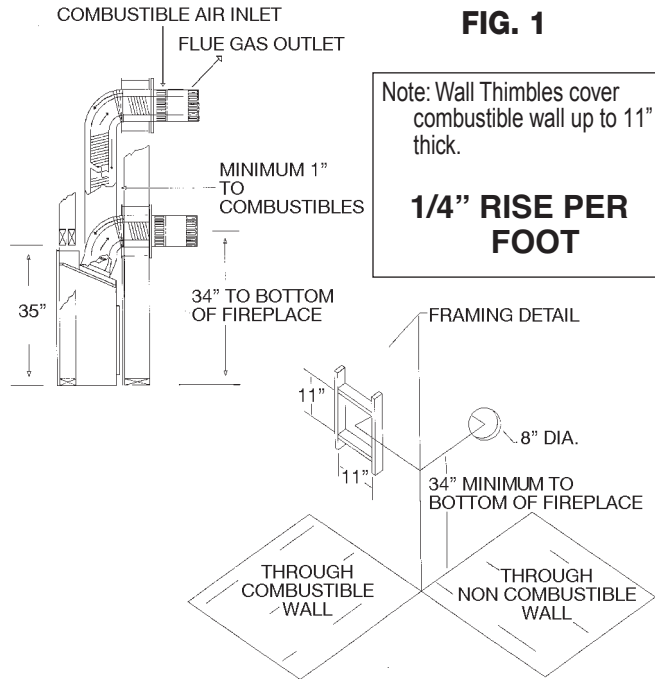

HBZDV4736

Minimum clearance to combustibles on venting
 Vertical 1" with Kingsman Vent System
 1 1/4" with Simpson Duravent Systems
 Top of Horizontal Pipe 1 1/2"
 Top of 90 degree bend in Minimum Enclosures of 50 1/2-56 1/2" is 2 1/2" with insulation Sleeve
 Top of 90 degree bend in enclosure over 56 1/2" -60" is 4 1/2" without insulation sleeve.
 Top of 90 degree bend in enclosures over 60" is 2 1/2" without insulation sleeve.

Louvered Unit Shown

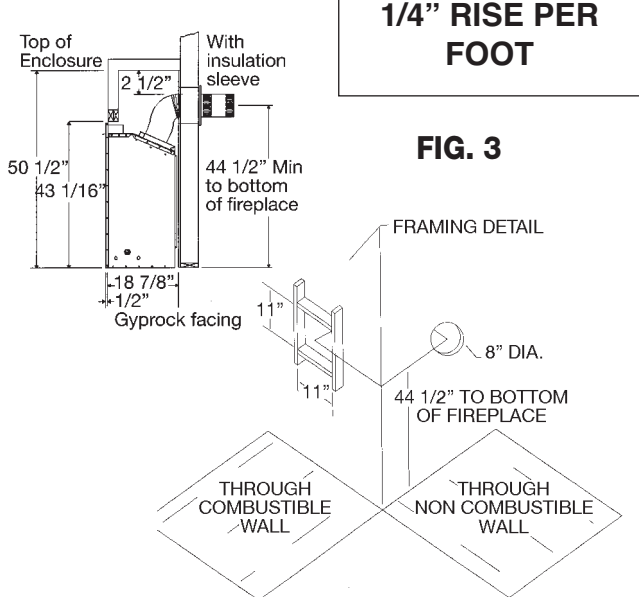

MQHBZDV4236/MQRB4236

Minimum clearance to combustibles on venting is 1" with the following exceptions: Top of horizontal 1 1/2". Top of 90 degree elbow in enclosures under 45" to 46" is 5". Top of 90 degree elbow in an enclosure over 46" is 2 1/2".

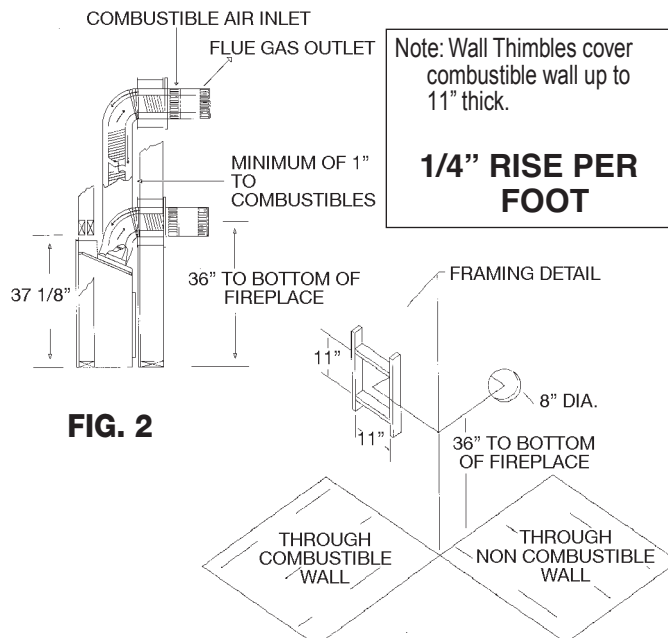

Venting Straight Up Through Roof

1. An Attic Insulation Shield must be installed where the vent passes from a lower living space into an attic space where the chimney is not enclosed. It is designed to keep insulation materials away from the chimney. See Fig. 1.
2. When installing the Attic Insulation Shield where the chimney passes from a living space to an attic space, install the shield from below and nail in place using 1" spiral nails.
3. A fire stop must be installed on the bottom side of the joists when passing through a ceiling or floor. If an attic insulation shield is to be used, a fire stop is not required.

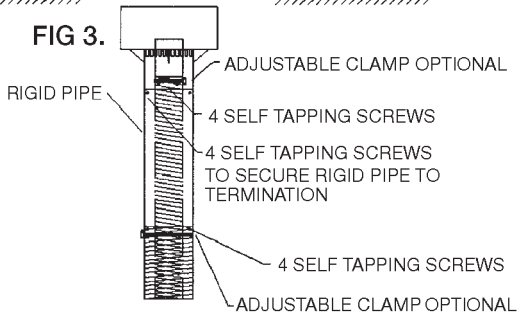
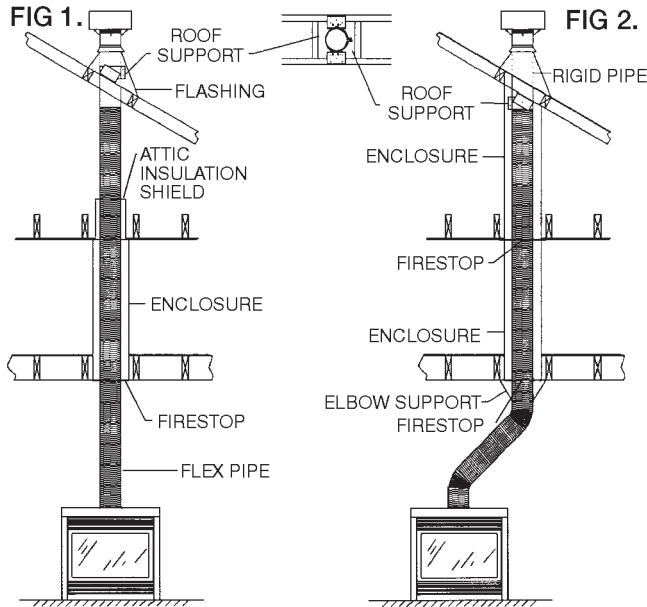

Using Flex Bends

4. Avoid cutting joists by offsetting the flex pipe. See Fig. 2.
5. When using 45° bends a bend support is required directly above the highest bend.
6. When installing a bend in a joist area a minimum of 2 1/2" clearance to combustibles to the top of bend must be maintained, sides and bottom of pipe, a 1" clearance to combustibles must be maintained. If running horizontal through an area a 1 1/2" minimum clearance to the top of the horizontal pipe must be maintained.
7. Maximum vertical height of system should not exceed 40 feet.
8. Use roof support and 7" rigid pipe at roof level. Flex not permitted within roof support.
9. When penetrating the roof a rigid 7" galvanized pipe must be used. Attach the 7" flex to the 7" rigid with high temperature sealant, secure with four screws assuring the flex and rigid pipe are secured. 4" flex pipe must be secured the same way with 4 screws but must penetrate the 4" flex and 4" section of termination. Attach 7" rigid pipe to 7" termination with sealant and screw with 4 sheet metal screws. (See Fig. 3).
10. Vertical termination clearance is 18" (inches) above the roof, measured from highest point of exit on the roof line.
11. Support vertical pipes to maintain minimum of one inch or greater clearances to combustibles.

Roof Flashing

Ensure that you have the proper roof flashing by checking your roof pitch using a level and two rulers, or by using a roof pitch card. See figure below.

Slide a Roof Flashing suitable to your roof slope over the vent. Place the edge of the flashing plate that will be on the higher part of the roof slope under the shingles. Both the sides and the lower edge lay on top of the shingles.

NOTE: At the top edge of the flashing plate, lift the shingles and nail the plate to the roof deck, then cement the shingles to the plate with a suitable waterproof mastic.

Ensure that the chimney is plumb. Square up the flashing plate and nail in place to the roof deck. Use 12 nails with neoprene washers or cover the heads with a suitable waterproof mastic.

Wrap the storm collar around the vent above the flashing. Secure the ends together loosely with nut and bolt supplied. Slide the collar down the vent until it comes in contact with the flashing. Tighten the bolt and seal the Storm Collar to the vent with a suitable waterproof non-combustible mastic.

The flashing and storm collar should be painted to match the roof shingles. This will extend its life and improve the appearance. Clean, prime and paint with suitable painting products.

Vertical Venting in Cold Climates

In cold climate conditions where temperatures go below -10 degrees Celsius or 14 degrees Fahrenheit, we recommend that the chase be insulated and where the vent pipe enters into the attic space that the pipe be wrapped with an insulated mylar sleeve. This will increase the temperature of the vent and help the appliance to vent properly in cold weather conditions.

It is also important in vertical vented direct vent appliances that the appliance be operated daily during the winter months as this will help stop the Termination from freezing up. We recommend using a thermostat set at room temperature to allow the unit to cycle.

For IPI models it may be necessary to set the appliance to Standing Pilot mode to maintain heat in the cavity. The purpose of this procedure is to prevent cold air from penetrating the chimney and then onto the living space. Therefore, when the internal temperature is slightly elevated the fireplace is able to freely exhaust its combustion and hence making it easier to startup

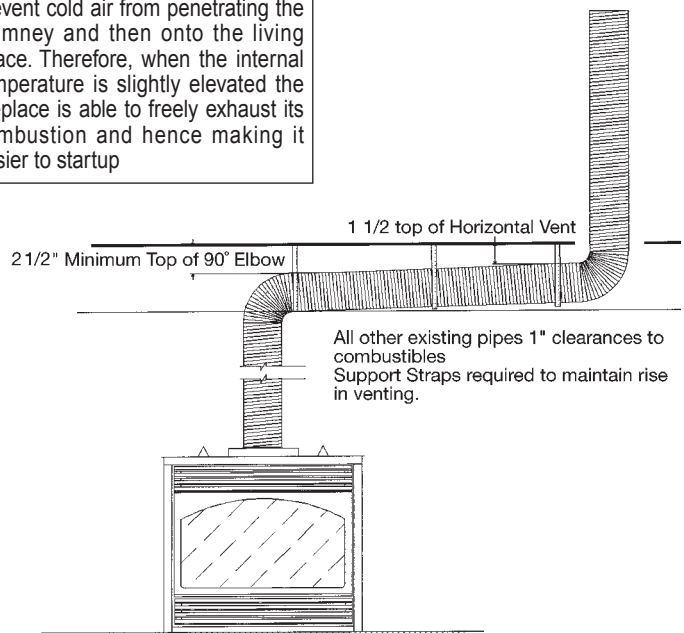
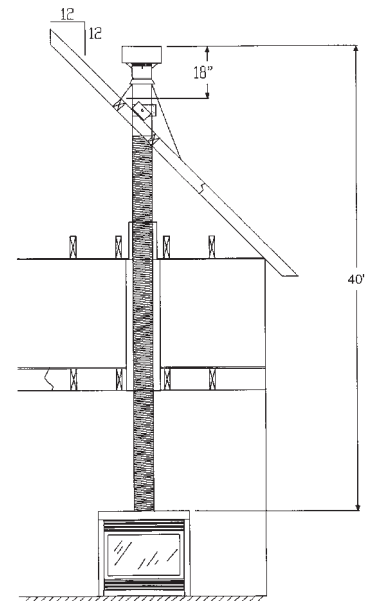

-Glass Safety- All Units

IT IS THE RESPONSIBILITY OF THE HOME OWNER TO ENSURE THAT NO ONE TOUCHES A HOT APPLIANCE.

If the barrier becomes damaged, the barrier shall be replaced with the manufacturer's barrier for this appliance.

Any safety screen, guard, or barrier removed for servicing the appliance, must be replaced prior to operating the appliance.

- Children and adults should be alerted to the hazards of the high surface temperatures of this appliance and should stay away to avoid burns or ignition of clothing.
- Do not clean when the glass is hot.
- Young children should be carefully supervised when they are in the same room as the appliance. Toddlers, young children and others may be susceptible to accidental contact burns.
- A physical barrier is recommended if there are at risk individuals in the house. To restrict access to a fireplace or stove, install an adjustable safety gate to keep toddlers, young children and other at risk individuals out of the room and away from hot surfaces.
- Do not leave the fireplace remote control where it is accessible to children.

 **DANGER**



HOT GLASS WILL CAUSE BURNS.

DO NOT TOUCH GLASS UNTIL COOLED.

NEVER ALLOW CHILDREN TO TOUCH GLASS.

A barrier designed to reduce the risk of burns from the hot viewing glass is provided with this appliance and shall be installed for the protection of children and other at-risk individuals.

-Termination Cap Safety- All Units

 **WARNING:**

A HORIZONTAL VENT CERTIFIED GUARD (SAFETY CAGE) IS AVAILABLE WHEN REQUIRED BY LOCAL CODES.

SAFETY CAGES ARE AVAILABLE FOR ALL HORIZONTAL VENT TERMINATIONS. CHECK WITH YOUR DEALER.

- **TERMINATION CAP IS HOT!** Do not place flammable materials on or within 24 inches of termination caps.
- It is imperative that the vent termination be located observing the minimum clearances as shown in manual.
- There must not be any obstruction such as bushes, garden sheds, fences, decks or utility buildings within 24" from the front of the termination plate.
- Do not locate termination where excessive snow or ice build-up may occur. Be sure to check vent termination area after snow falls and clear to prevent accidental blockage of venting system. When using snow blowers, make sure snow is not directed towards vent termination area.
- Venting terminal shall not be recessed into a wall or siding.

Approved for Power Vent PVH58

- This appliance is approved for use with the Kingsman PVH58 Horizontal Power Vent -

The PVH58 Horizontal Power Vent Termination is intended for use where standard venting configurations are not possible.

NOTE: MODELS EQUIPPED WITH MILLIVOLT/ STANDING PILOT IGNITION: Downward vertical vent runs are **NOT** permitted.

NOTE: MODELS EQUIPPED WITH INTERMITTENT PILOT IGNITION (Proflame 1 or Proflame 2): Downward vertical vent runs are permitted, however, Cold Climate Switch (Standing Pilot Mode) must **NOT** be used.

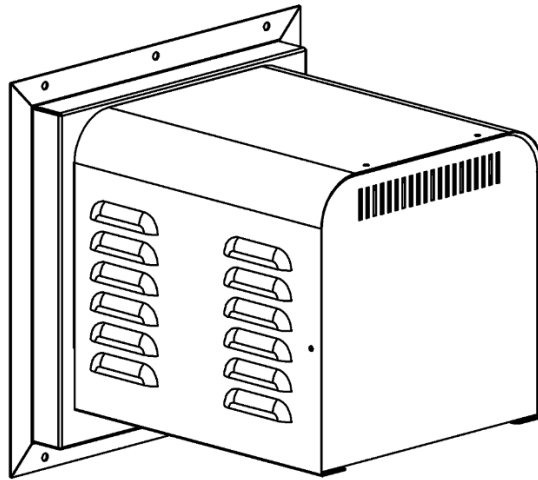

PVH-58 Maximum / Minimum Vent Lengths:

Maximum Vent Length is 125 ft plus six 90° elbows with Air Intake Shutter fully closed. Termination must not be below unit.

This power vent can be installed up to **8ft** below the installed fireplace on runs less than 100ft and not more than four 90° elbows.

Minimum Vent Length is 1 FT vertical x 3 FT horizontal x 3 FT vertical x 3 FT horizontal (See PVH58 manual).

Seven 90° elbows are possible if the total horizontal is not more than 25ft and the vertical does not exceed 15ft.

Refer to PVH58 Manual for proper installation and use.



PVH58 POWER VENT PARTS LIST

NUMBER	DESCRIPTION
--------	-------------

PVH58	Horizontal Power Vent Termination
PVC58MV	Power Vent Control Module – Millivolt Box
PVC58IPI	Power Vent Control Module – IPI Box
PVH20H	Main Wiring Harness Assembly – Extension Harness (20ft)

4/7 VENTING AND VENTING ADAPTERS

For fireplaces to be converted to hard pipe (DuraVent-DirectVent Pro, etc.) at the fireplace:

ZDVDKA	DuraVent Fireplace Adapter (ZRB46 Only)
ZDVDFDA	DuraVent Fireplace Adapter
ZDVDDIA	DuraVent Pipe Increaser (Adapts 4/6-5/8" venting to 5/8")

For Power Vent installations where flex pipe will be used up to the Power Vent unit:

Z47PVA	Pipe Reducer 8"Sm – 7"Sm, Pipe Reducer 5"Sm – 4"Sm (Adapts PVH58 to accept 4/7" Flex Pipe
--------	---

*** One 12" section of hard pipe must be connected directly to the Power Vent before any adapters are connected.**

Order the appropriate lengths of venting (see below).

ZDVFK5	Flex Kit (4" & 7" Dia.) x 2.5' (Unexpanded) 5' Expanded
ZDVFK8	Flex Kit (4" & 7" Dia.) x 4' (Unexpanded) 8' Expanded
ZDVFK20	Flex Kit (4" & 7" Dia.) x 10' (Unexpanded) 20' Expanded
	*Kits are complete with spring stand-offs & silicone.
ZDV4FC	Flex Connector 4" Diameter
ZDV7FC	Flex Connector 7" Diameter
ZDV4SS	Spring - Standoff Spacer for Inner Pipe



LIMITED LIFETIME WARRANTY

This Limited Lifetime Warranty applies only while the unit remains at the site of the original installation and only if the unit is installed inside the continental United States, Alaska, Hawaii, and Canada. The warranty applies only if the unit is installed and operated in accordance with the printed instructions and in compliance with applicable installation and building codes and good trade practices.

BASIC ONE YEAR WARRANTY

During the first year after installation, we will provide a replacement for any component part of your unit found to be defective in materials or workmanship, including labour costs. Repair work requires prior approval by Kingsman, labour costs are based on a predetermined rate schedule and any repair work must be done through an authorized Kingsman dealer.

(Excluded Components: Accent Light Bulbs, Gasketing and Paint)

LIMITED LIFETIME WARRANTY

The heat exchanger, combustion chamber and burner of every Kingsman product excluding the Outdoor Firepit are warranted against materials or workmanship during the period the product is owned by the original owner. The part to be replaced must be returned to our distributor in exchange for the replacement part. Any labor, material, freight and/or handling charges associated with any repair or replacement pursuant to this Limited Lifetime Warranty will not be covered by this warranty.

GENERAL TERMS

In lieu of providing a replacement part, we may, at our option, provide the distributor's component purchase price from us or a credit equal to the distributor's component purchase price from us toward the purchase of any new unit which we distribute. If a credit is given in lieu of a replacement part, the rating plate from the unit being replaced must be submitted on a warranty claim, and the unit being replaced must be made available to our distributor for disposition.

In establishing the date of installation for any purpose, including determination of the starting date for the term of this Limited Lifetime Warranty, reasonable proof of the original installation date must be presented*, otherwise the effective date will be based upon the date of manufacture plus thirty (30) days.

We will not be responsible for and you, the user, will pay for: (a) damages caused by accident, abuse, negligence, misuse, riot, fire, flood, or Acts of God (b) damages caused by operating the unit where there is a corrosive atmosphere containing chlorine, fluorine, or any other damaging chemicals (other than in a normal residential environment) (c) damages caused by any unauthorized alteration or repair of the unit affecting its stability or performance (d) damages caused by improper matching or application of the unit or the unit's components (e) damages caused by failing to provide proper maintenance and service to the unit (f) any expenses incurred for erecting, disconnecting or dismantling the unit (g) parts or supplies used in connection with service or maintenance (h) damage repairs, inoperation or inefficiency resulting from faulty installation or application (i) electricity or fuel costs or any increase in electricity or fuel cost whatsoever including additional or unusual use of supplemental electric heat.

We shall not be liable for any incidental, consequential, or special damages or expenses in connection with any use or failure of this unit. We have not made and do not make any representation or warranty of fitness for a particular use or purpose, and there is no implied condition of fitness for a particular use or purpose. We make no express warranties except as stated in this Limited Lifetime Warranty. No one is authorized to change this Limited Lifetime Warranty or to create for us any other obligation or liability in connections with this unit. Any implied warranties shall last for one year after the original installation. Some states and provinces do not allow the exclusion or limitation of incidental or consequential damages or do not allow limitations on how long an implied warranty or condition lasts, so the above limitations or exclusions may not apply to you. The provisions of this limited warranty are in additions to and not a modification of or subtraction from any statutory warranties and other rights and remedies provided by law.

Save this certificate. It gives you specific legal rights, and you may also have other rights which may vary from state to state and province to province.

In the event your unit needs servicing, contact your dealer or contractor who installed or serviced your unit. When requesting service, please have the model and serial number from each unit readily available. If your dealer needs assistance, the distributor is available for support and we, in turn support the distributor's efforts.

Fill in the installation date and model and serial numbers of the unit in the space provided below and retain this limited warranty for your files.

Model No. _____ Serial No. _____ Date installed _____

Dealer or Contractor Name: _____

*To receive advantage of your warranty, you must retain the original records that can establish the installation date of your unit.